

**DYNAMIK DURCH  
WIDERSTAND**

***DYNAMICS  
THROUGH RESISTANCE***

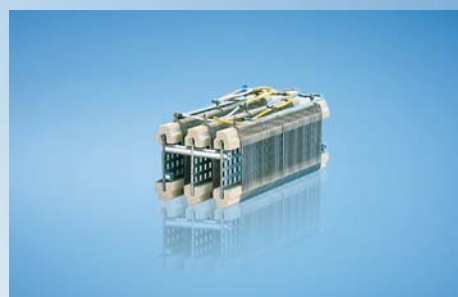

**FRIZLEN**  
LEISTUNGSWIDERSTÄNDE  
POWER RESISTORS

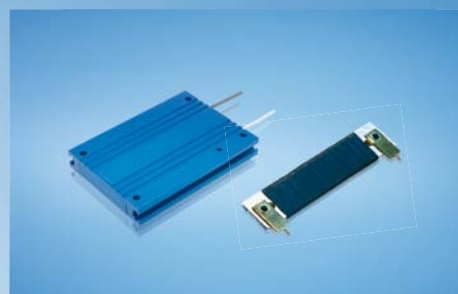

## **DYNAMIK DURCH WIDERSTAND**

**Wir über uns**

## **DYNAMICS THROUGH RESISTANCE**

**About us**

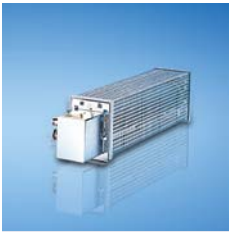

### **DIE KLASSIKER**

**Drahtgewickelte Rohrfestwiderstände**  
10 bis 6000 Watt

### **THE ORIGINAL ONES**

**Wirewound tubular fixed resistors**  
10 up to 6000 Watt



### **DIE FLEXIBLEN**

**Zementierte  
Drahtdrehwiderstände**  
16 bis 1500 Watt

### **THE FLEXIBLE ONES**

**Cement coated wirewound  
variable resistors**  
16 up to 1500 Watt

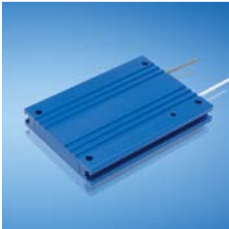

### **DIE INNOVATIVEN**

**Drahtgewickelte Flachwiderstände,  
auch gekapselt und in wassergekühlter  
Ausführung**  
5 bis 40000 Watt

### **THE INNOVATIVE ONES**

**Wirewound flat resistors,  
also enclosed and  
watercooled**  
5 up to 40000 Watt



### **DIE BELASTBAREN**

**Last- und Prüfwiderstände**  
0,01 bis 250 Kilowatt

### **THE LOADABLE ONES**

**Load- and test resistors**  
0.01 up to 250 Kilowatt



### **DIE MODULAREN**

**Drahtgewickelte  
Lamellenfestwiderstände**  
0,15 bis 30 Kilowatt

### **THE MODULAR ONES**

**Wirewound lamina type  
fixed resistors**  
0,15 up to 30 Kilowatt



### **DIE ROBUSTEN**

**Stahlgitterfestwiderstände**  
0,5 bis 250 Kilowatt

### **THE ROBUST ONES**

**Steel-grid fixed resistors**  
0,5 up to 250 Kilowatt



### **FRIZLEN SONDERGERÄTE**

**DC-POWERSWITCH**  
**Kundenspezifische Widerstandsgeräte**

### **FRIZLEN SPECIAL DEVICES**

**DC-POWERSWITCH**  
**Customised resistor units**

## Das richtige Produkt für Ihre Anwendung

## Suitable products for your application

Anwendungen	Application	Typleistung [kW]		Produktgruppe					
		min.	max.	T 100	T 200	T 300	T 400	T 500	T 600
Bremswiderstände für Frequenzumrichter- und Gleichstromantriebe	<i>Braking resistors for frequency converters and DC drives</i>	0,01	40,0			X		X	
		0,01	6,0	X				X	X
		6,0	30,0					X	X
		30,0	250						X
Belastungswiderstände für Spannungsquellen, Batterien, USV-Geräte, Generatoren und Netzgeräte	<i>Load resistors for supply units, power packs, batteries, UPS units and generators</i>	0,01	250				X		
Stufenlose Drehzahlverstellung von kleinen Gleich- und Wechselstrommotoren	<i>Stepless variable speed adjustment for small AC and DC motors</i>	0,01	1,5		X		X		
Feldsteller für Generatoren, Widerstände zur Strom- und Spannungsbegrenzung	<i>Field rheostats for generators, resistors for current and voltage limitation</i>	0,01	3,8	X	X				
Motorische Potentiometer als fernbetätigte Sollwertgeber	<i>Motorised potentiometers as nominal value setters</i>	0,01	1,5		X				
Widerstandsbaugruppen für Einbau in leistungselektronische Geräte	<i>Resistor modules fitting into electronic power devices</i>	0,01	0,75	X		X		X	
		0,3	2,0					X	
Anlass- und Stellwiderstände für Schleifringläufer- und Gleichstrommotoren	<i>Starting and regulating resistors for slip-ring rotor and DC motors</i>	0,15	30,0					X	
		0,5	250						X
Ständer-Vorschaltwiderstände für Kurzschlussläufermotoren	<i>Stator series resistors for squirrel-cage motors</i>	0,5	250						X
Strombegrenzungswiderstände zur Ladung und Entladung von Kondensatoren	<i>Resistors for current limitation e.g. for charging and discharging of capacitors</i>	0,01	1,0	X		X		X	
Experimentier- und Prüfwiderstände in Laboratorien, Schulen und Universitäten	<i>Resistors for experimenting and testing in laboratories, schools and universities</i>	0,01	50				X		
Widerstände zur Schutzbeschaltung, Filterwiderstände	<i>Protective resistors, filter resistors</i>	0,01	0,75	X		X		X	
		0,75	6,0	X				X	
		1,5	22,0						X



## Wir über uns

Mit FRIZLEN Leistungswiderständen haben Sie elektrische Leistung voll im Griff.



Unser umfassendes Know-how zeigt sich im kompletten Spektrum vom Einzelstück bis zur Serie, für Leistungen von 5 Watt bis 250 Kilowatt.



Einsatz- und Anwendungsgebiete stellen die Anforderungen, die Lösungen entwickeln wir.

Ihrem Anforderungsprofil entsprechend berechnen und fertigen wir Widerstände und Widerstandskombinationen unter Berücksichtigung Ihrer Vorgaben. Natürlich beraten wir Sie gern und ermitteln auf Wunsch die Widerstandsdimensionierung mit Hilfe EDV-gestützter Berechnung und Simulation.

Hochwertige Standard- sowie Sonderlösungen von FRIZLEN sorgen für Dynamik im Verbund mit leistungselektronischen Geräten in Maschinen und Anlagen. Bewegung zu stoppen, konstant zu halten und exakte Abläufe zu ermöglichen – dabei unterstützen wir die elektrische Antriebstechnik und verbessern so die Dynamik Ihrer Antriebe.

## About us

*Keep your electric power under control with FRIZLEN power resistors.*

*Our extensive know-how is demonstrated in a complete spectrum from single item up to series production, for power values from 5 watts up to 250 kilowatts.*

*Different ranges of use and application set the requirements, we provide the solutions.*

*We design and produce resistors and resistor combinations exactly to meet your requirements. We are, of course, happy to advise you according to your specification. Upon request, we can determine resistor dimensioning using our computer-supported calculation and simulation system.*

*High-quality standard and special solutions from FRIZLEN ensure dynamics when you are dealing with high performance electrical equipment in machines and processes. We support electrically driven power engineering by stopping movement, keeping it constant and ensuring exact sequences, which improves the dynamics of your drive systems.*

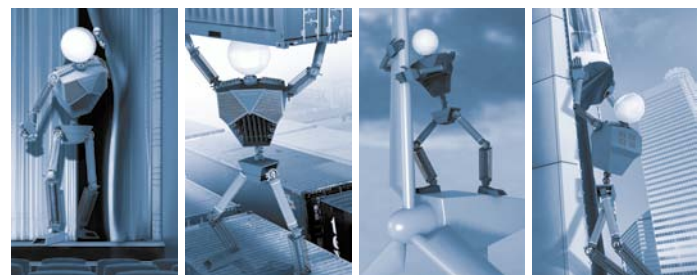





### Stahlgitterfestwiderstände

0,5 bis 250 Kilowatt

Stahlgitterfestwiderstände als Einzelelemente, die einbaufähig sind und daraus aufgebaute Stahlgitterfestwiderstandsgeräte in verschiedenen Schutz- und Befestigungsarten.

- Mit und ohne Abdeckung mit Anschluss am Widerstand oder an Klemmen in Schutzart IP00, IP20 oder IP23
- Für Wand- oder Bodenmontage oder für Kanaleinbau
- Thermisches Überstromrelais, Temperaturschalter oder FRIZLEN DC-Powerswitch für thermische Überwachung und Abschaltung
- Fremdbelüftet für große Leistungen, Parallelschaltung von Geräten für Leistungen größer 250 kW

### Steel-grid fixed resistors

0,5 up to 250 Kilowatt

Steel-grid fixed resistors as individual components, that can be integrated into other units and composed to steel-grid fixed resistor units in different degrees of protection and mounting types.

- With or without cover, connection direct to the resistor or on terminals in degree of protection IP00, IP20 or IP23
- For horizontal and vertical mounting and for integration into exhaust air installations
- Thermal overload relay, temperature switch or FRIZLEN DC-Powerswitch for thermal monitoring and switch off
- Forced ventilation for higher dissipation, switching in parallel of units for dissipation > 250 kW



## Contents

This list comprises steel-grid fixed resistors as individual components in the production series S, as well as resistor blocks in the series FE and FK.. that can be integrated into other units and composed to steel-grid fixed units in different degrees of protection and mounting types

<i>maximum typical power</i>	<i>characteristics</i>	<i>type series</i>	<i>page</i>
	general survey		<b>T612E</b>
	technical details		<b>T613E</b>
0,5 kW	suitable for integration, individual elements	S 1 – S 31	<b>T621E</b>
22 kW	suitable for integration, with threaded bolt M12	FE 31..	<b>T622E</b>
22 kW	suitable for integration, with flat side-plates	FKE 31..	<b>T623E</b>
22 kW	flat construction form, 2 terminals, various types	FGF.. 31..	<b>T624E</b>
12 kW	for switch cabinet, 2 terminals	FGHD.. 31..	<b>T626E</b>
66 kW	for integration with great rated power	FK 3..	<b>T627E</b>
250 kW	in canal construction	FKK 3..	<b>T628E</b>
66 kW	for floor mounting, also IP 23	FA 3../FS 3..	<b>T629E</b>
5,0 kW	for wall mounting, IP 23	FS 319.. / 320..	<b>T630E</b>
500 kW	various wattage rating, with forced ventilation	FSV 3.. / FAV 3..	<b>T631E</b>
0,5 kW	suitable for integration, individual 3 mm elements	S301G – S321G	<b>T632E</b>

## Properties

- **very favourable price-performance-ratio**  
⇒ high power, high quality and low budget
- **individual components in 31 different resistor element values**  
⇒ high ampacity up to 122 A per steel-grid fixed resistor, may be enlarged by switching in parallel
- **lower temperature coefficient than cast iron resistors**  
⇒ therefore smaller dependence of the resistor value on temperature than cast iron resistors
- **high heat capacity**  
⇒ overload resistant at short time load
- **very robust construction**  
⇒ insensitive to vibrations
- **enclosures made from hot galvanised steel sheet**  
⇒ various protection and mounting types (all series besides S and FE)
- **temperature switch available**  
⇒ integrated warning for temperature monitoring (optional with many series)
- **thermal overload relay available**  
⇒ integrated warning for high operating security (serialized with series FGFT)
- **UL-recognition for American and Canadian market (E212934)**  
⇒ on request for all marked series available



## Applications

- braking resistors for frequency converters and DC drives as well as railway applications
- load resistors for emergency units, generators, motors and electronic power sources
- starting resistors for DC motors
- stator resistors for squirrel-cage motor
- starting and regulating resistors for slip-ring rotor motor
- discharge resistors for batteries
- earthing resistors for low-voltage mains supplies



### T 600 – Survey

type series	S1 - S31 a. S301G-S321G	FE. 31..	FKE. 31..	FGF.. 31..	FGHD. 31..	FK. 3..	FKK. 3..	FA./FS. 3..	FS 319.. - 320..	F.V 3..	
	characteristics Symbol	page	621E 632E	622E	623E	624E 625E	626E	627E	628E	629E	630E
power from [kW]		0,5	1,0	1,0	1,0	1,0	1,5	5,0	1,5	0,5	70
power up to [kW]		0,5	22	22	22	12	66	250	66	5,0	500
max. number of terminals (without temperature switch)		-	-	-	2	2	40	6	40	2	40
protection degree IP00		X	X	X			X	X			
protection degree IP20 - if mounted on an appropriate surface					X	X					
protection degree IP20									X		X
protection degree IP23									X	X	X
horizontal mounting			X	X							
vertical mounting			X	X							
horizontal mounting					X		X	X	X		X
vertical mounting					X	X		X		X	
temperature switch (optional)			X	X	X	X	X	X	X	X	
thermal overload relay					X						
connection at lugs at the resistor		X	X	X							
integration possible		X	X	X		X	X				
forced ventilation											X
with  US Recognition		X	X	X	X	X	X		X		

Rights for improvements and modifications of our products reserved.  
Modifications, errors and misprints justify no claim for damages.  
We refer to our terms of sales and delivery.

**Technical details**

*Construction*  
Steel-grid fixed resistor  
elements  
Type series S

Our steel-grid fixed resistor elements (SG) are made out of chromium alloyed and heat-resistant steel sheets of alloy X10CrAl13 (material # 1.4724), which has a high specific resistance value of 0,75  $\Omega \times \text{mm}^2/\text{m}$ . Both long sides of the SG are punched with slots in a meander-shaped current path. The ohmic value depends on the width of the straps. They are mechanically reinforced by strips of stainless steel with inlays of mica.

*Spectrum*

By the use of SG with a big ohmic range of 0,022  $\Omega$  to 6,8  $\Omega$  and a typical power of 500 W per steel-grid we can achieve a wide range of resistance and power values by variation of steel-grid number and ohmic value.

*Resistance values/  
Production tolerance/  
Temperature dependency*

Steel-grid fixed resistor elements have a smaller dependence of the resistance value on the steel-grid temperature than cast iron resistors, however a noticeably higher one than wire-wound resistors. The resistance value increases approx. 15% between cold and operating temperature.

The given rated resistance values of each individual SG in the table on page T621E are about 8% higher than the resistance value in cold condition and about 7% below the resistance value at the operating temperature.

The production tolerance is  $\pm 10\%$ .

*Energy absorption  
capacity/  
Time constant*

The energy absorption capacity varies per SG at a temperature increase of 300 K in dependency of the ohmic value between 50 and 70 kW. s.

The average thermal time constant is 100 s.

*Resistor blocks  
Type series FE*

If larger power ratings are to be obtained, several SG are assembled by M12-thru bolts and isolating mica tubes to a resistance block. The isolation between 2 neighbouring SG is effected by glazed ceramic rolls, the current conduction by stainless steel rolls. The resistance block is prestressed by cup springs and so held under constant contact pressure. In addition to that individually screwed conductor rolls between two neighbouring SG are possible. A resistor block may consist of identical SG or of different SG with lugs as taps.

*Resistors  
Type series FK; FGF; FA; FS*

In order to facilitate the integration, and/or to provide different degrees of protection, various kinds of enclosures are used. The enclosures are manufactured out of hot-galvanized and perforated steel sheet and therefore are well protected against corrosion. Also an extra varnish in RAL 7032 is available with an additional charge as well as enclosures in stainless steel (alloy 1.4301/AISI 304).

*Degrees of protection*

IP  
00

IP  
20<sup>①</sup>

IP  
20

IP  
23

Correlation of type series and degrees of protection according to EN 60529 and/or DIN VDE 0470 part 1

Type series	Degree of protection	First digit degree of protection against access & solid foreign objects	Second digit degree of protection against water
S FE FK..	IP 00	Non-protected – i.e. depending upon integration the user must provide a protection	Non-protected
FGF..	IP 20 <sup>①</sup>		Non-protected
FA.. FAV..	IP 20	Protected against access to hazardous parts with a finger and against solid foreign objects of 12,5mm $\varnothing$ and greater.	Non-protected
FS.. FSV..	IP 23		Protected against spraying water. Water sprayed at an angle up to 60° on either side of the vertical shall have no harmful effects. (for outdoor location)

<sup>①</sup>if mounted on an appropriate surface – i.e. mounted on a surface according to degree of protection IP 20 or higher





### Protective measures



All our power resistors with degree of protection IP 20<sup>①</sup> or higher correspond to safety class system I, i.e. we provide connections for protective earth conductors according to EN 61140.

Devices with degree of protection IP 20 or higher correspond to the CE low voltage directive.

Power resistors being passive electrical or electrical units are not affected by the specific EMC standards. They do not produce any interfering radiations nor are they affected.

### Air and creepage distances

Air and creepage distances are rated according to IEC 664 (DIN EN 0110 part 1) for the overvoltage category III and degree of pollution 3 for grounded three-phase mains supplies up to 3 x 500 V. Testing voltage 2.5 kV AC.

These data are valid for all devices that are connected to mains voltage and derived voltages, as for example the intermediate circuit voltage of frequency converters.

Do not conclude from the calculated relation between the rated power and the maximum producible ohmic value to the rated voltage!

### UL-recognition



All important type series do have an UL- recognition both for the American and for the Canadian market. The devices were certified according to UL 508 under the number E212934. This recognition is the same as a recognition according to CSA C22.2 No.14. For further information please check the UL-flyer.

(Please ask for it or visit us at [www.frizlen.com](http://www.frizlen.com))

### Excess current protection

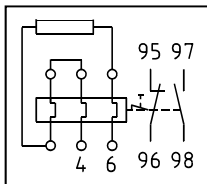

A protection of the resistors against overloading or excess temperature - as demanded in standards - can be realized with the help of a thermal overload relay provided by the user. The set current must correspond to the rated current of the resistor, that is calculated according to continuous duty power and resistance value corresponding to Ohm's law (formula: see "terminal details" p. T618E).

Concerning the series FGFT the thermal overload relay is a component of the device - with exceeding of the rated current a signal contact is released. There will not be a disconnection of the resistor. Resetting by hand.

### Excess temperature protection

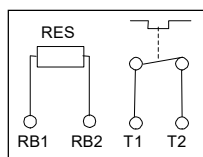

Another kind of the excess temperature monitoring, particularly suited for long-term overloading, is the equipment with a temperature switch. In IP 20/23-resistor devices it is wired on terminals, in IP 00 resistors the switch is directly connectable and releases a signal contact, when the set temperature is exceeded. There will not be a disconnection of the resistor. See type series FEQ / FKEQ / FGF.Q / FKQ / FAQ / FSQ / F.VQ



**Attention: The function of our monitoring device with temperature switch and thermal overload relay is only correct operating when the resistor is working with his given maximum typical power.**

**You can inform yourselfs about function and restrictions by our data sheet „Tripping of monitoring devices“.**

We can send it to you on request.

**Contact rating**

Contact ratings of the signal contacts of temperature switches and thermal overload relays:

- 2 A / 24 VDC (DC11)
- 2 A / 230 VAC (AC11)

Contact ratings of the signal contacts of the DC-POWERSWITCH:

- 5 A / 24 VDC (DC11)
- 10 A / 230 VAC (AC11)

**Starting up**

Resistors in industry version.

On first operation during commissioning, the steelgrid resistors will produce some smoke. This is due to the lubricant used in the manufacturing process of the resistor element.

**Storage temperature/  
Operation temperature/  
Installation altitude**

Storage temperature: - 40° C to 80° C

Operation temperature: - 30° C to 40° C. If the ambient temperature is higher than 40°C, you have to decrease the continuous dissipation by 4% per 10 K temperature rise!

Installation altitude: 2000 m above sea level, you have to decrease the continuous dissipation for 10% per 1000 m altitude, maximum altitude 5000 m above sea level

Restrictions are to be made for the type series FGFT. because of the built-in monitoring device. Operation temperature: - 20° C to 40° C.

**Typical power/  
Continuous dissipation/  
Ventilation / temperatures**

The given typical power values are valid for 100% duty cycle factor (DCF) (continuous dissipation) under the following conditions:

- temperature rise of 200 K at the surface of fixed resistor enclosures (degree of protection > IP00)
- temperature rise of 300 K at the surface of fixed resistor elements (degree of protection IP00).
- unhindered access of cooling air
- unhindered diverting of warmed up air (mind a minimum separation distance of approx. 200 mm to neighbouring components/walls and of approx. 500 mm to components above/ceiling)

**Ventilation / temperatures**

Since electrical energy is converted into heat, heating up of the exhaust air and of the enclosure at the air outlet is inevitable.

The highest temperature with typical power may be maximum 200°C above the ambient temperature. Since the cooling of the devices is accomplished by convection and/or forced ventilation (series FAV/ FSV), the above mentioned aspects have absolutely to be considered.



**In cases of insufficient cooling or false mounting the resistor or the surrounding devices units could be overheated or ruined.**



Depending upon use it can be possible to increase the continuous dissipation of the resistors, if higher temperatures are accepted. With an increase of e.g. of 130% of the typical power you will have a rise in temperature of 350K at the surface of the resistor. In multi-storeyed resistors and in protection degree IP23 with waterproof roof is it possible to receive a temperature rise up to 500K. In other cases of applications the continuous dissipation must be reduced, for example with temperature sensitive devices in the surrounding. The dependence between temperature rise and actual continuous dissipation is shown in the diagram below.

*Excess temperature in dependence of continuous dissipation*

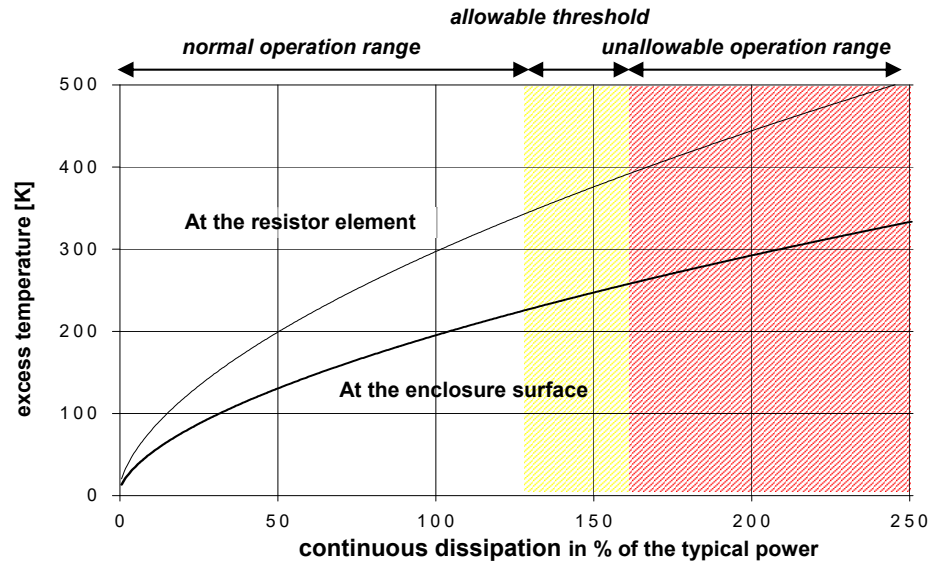

**Normal operation range (up to 130%):**

Recommended operation range for maximum product life and failure free operation

**Allowable threshold (up to 160%):**

Allowable operation range, danger of shorter product life and higher failure probability

**Unallowable operation range (more than 160%):**

Danger of excessive heat and destruction of resistor and neighbouring components



**Attention:** The function of our monitoring device with temperature switch and thermal overload relay is only correct operating when the resistor is working with his given maximum typical power.



Short time dissipation/  
Total cycle time/  
Duty cycle factor(DCF)

At many applications resistors are not loaded in continuous but in short time operation. In the following you will find indications, how to calculate the allowable short time dissipation with the help of the duty cycle factor (DCF) and the overload factor (OLF). If the DCF factor is not known, it can be calculated as follows:

$$\text{Duty cycle factor(DCF)} = \frac{\text{Switch on time}(t_{on})}{\text{Total cycle time}}$$

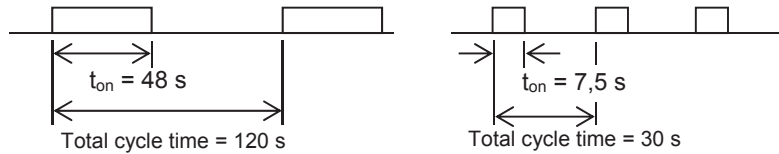

$$DCF_1 = \frac{48s}{120s} = 0,4 = 40\%$$

$$DCF_2 = \frac{7,5s}{30s} = 0,25 = 25\%$$

Warning: The total cycle time may be maximum 120 s - shorter total cycle times are possible.  
The total cycle times for motors are mostly higher than 120 s

Overload factor(OLF)

By comparison of the known DCF-factor with the following diagram or table you can work out the overload factor (OLF) and/or the continuous and the short time dissipation.

Overload factor (OLF) in dependence of duty cycle factor (DCF)  
(Total cycle time = 120s)

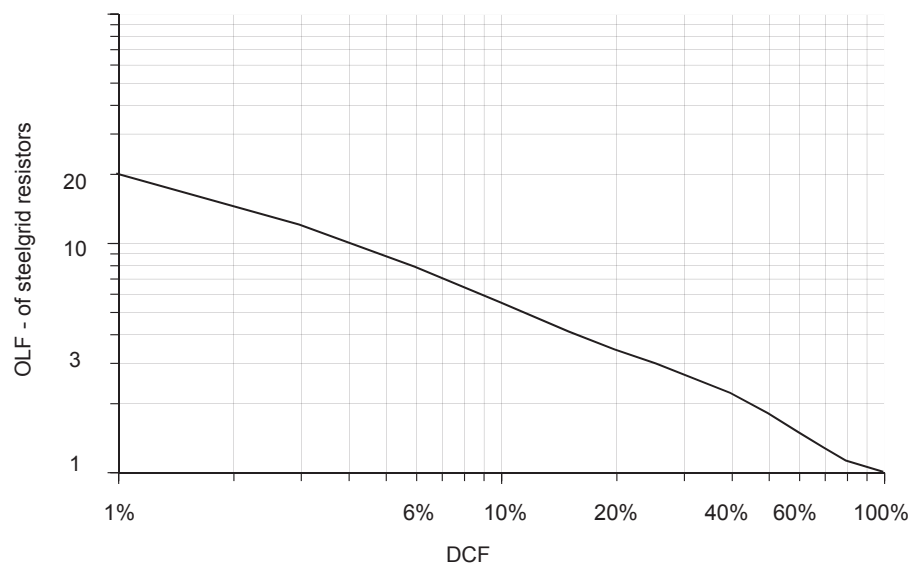

DCF	1%	3 %	6%	15%	25%	40%	60%	80%	100%
OLF	20	12	7,6	4,0	3,0	2,2	1,5	1,12	1,0

The continuous and the short time dissipation can be calculated as follows:

$$\text{Short time dissipation} = \text{Continuous dissipation} \times \text{OLF}$$

$$\text{Continuous dissipation} = \frac{\text{Short time dissipation}}{\text{Overload factor(OLF)}}$$

Calculation example  
given:

wanted:  
continuous dissipation

- Resistor with a short time dissipation of 100 kW for 48 s and a total cycle time of 120s
  - The duty cycle factor (DCF) is  $48\text{ s} : 120\text{ s} \times 100\% = 40\%$
  - Overload factor (OLF) for 40% DCF, according to table it is 2,2
  - The continuous dissipation is  $100\text{ kW} : 2,2 = 45,5\text{ kW}$ ;
- ⇒ You need a resistor with a continuous dissipation of at least 45,5 kW!





*Terminal details/  
Monitoring devices/  
Cross section*

Rated current and cross section of terminals and monitoring types.

Type	abbreviation	rated current in A with 100% DCF	rated current in A with 40% DCF	maximum cross section
porcelain terminal	PK	16		up to 2,5 mm <sup>2</sup>
ceramic flat terminal	FK	35	44	2,5 - 10 mm <sup>2</sup>
device terminal out of Polyamid (PA)	G 5	30	38	0,5 – 2,5 (4) mm <sup>2</sup> AWG 24 - 12
	G 10	60	75	0,5 – 10 (16) mm <sup>2</sup> AWG 20 - 6
bolt terminals out of ceramic	BK M6	60	75	cross section depending on lug size with corresponding hole
	BK M8	115	143	
	BK M10	220	287	
	BK M12	400	536	
feed-through terminal out of PA	HDFK4	30	38	up to 4,0 mm <sup>2</sup> ; AWG 24 - 12
	HDFK10-HV	65	82	up to 10 mm <sup>2</sup> ; AWG 20 - 6
cage clamp terminal out of PA	ST2,5	20	25	up to 2,5 mm <sup>2</sup> ; AWG 26 - 12
	ST 4	30	38	up to 4,0 mm <sup>2</sup> ; AWG 20 - 10
thermal overload relay	signal contact	2	-	up to 2,5 mm <sup>2</sup> ; AWG 16-12
	main connection	13/24/80	17/30/100	2,5/4/25 mm <sup>2</sup> ; AWG 20 - 6

The values in the brackets are valid for solid conductor or single-wired.

The rated current is calculated in each case due to the Ohm's law as follows:

$$I = \sqrt{\frac{P}{R}}$$

whereas  
P is the power of the resistor and  
R ist he value of the resistance

### Wiring

If terminals are required, the connections are wired by means of flexible, heat resistant, silicone-insulated wire on a terminal strip that is located in the lower and/or front part of the equipment within the area of the entering cooling air. If the wiring is accomplished by the user, make sure that a heat resistant wire is used.

For the UL-versions we use wires with UL-admission (other wire-isolations on request). For the type series FK /FA /FS 3.. and for F.V 38.. there is an undrilled cable entry strip in the lower part. It can be provided by the user with appropriate drillings for cable glands as strain relief.

### Mounting

Please mind the mounting indications in the corresponding type series!  
You will find these icons in the data sheets:

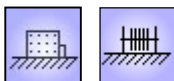

Allowable: On horizontal surfaces

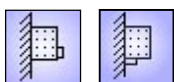

Allowable: On vertical surfaces terminals at the bottom



**Not** allowable: On vertical/horizontal surfaces terminals at the top, left or right



Allowable: On vertical surfaces



### Selection of Type series and dimension

The tables on the following data sheets contain a selection of the available equipment assemblies and/or the appropriate maximum assembly of the respective size of the device. Less steel-grids (SG) are possible.

For all type series, except for S, the following type codes are shown to explain the complete type designations.

#### Type code 1

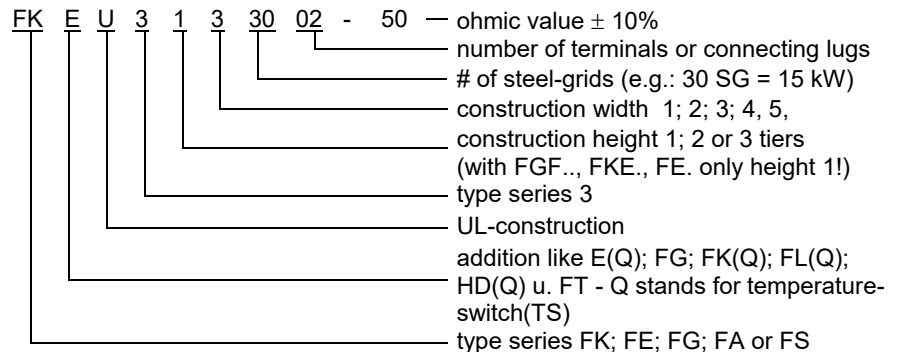

#### Type code 2

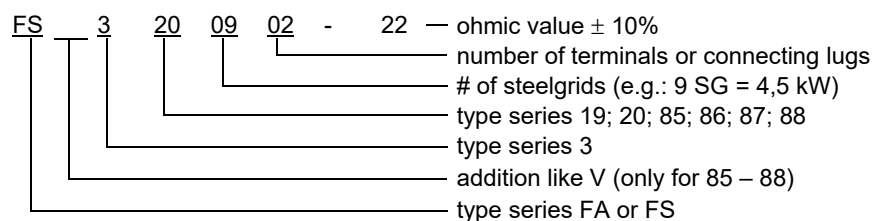

Type series S represents individual components. You can see their complete type designation in the table on p. T621E.



Devices that are built according to UL standard are marked additionally with "U" at the last position in the sequence of letters- see type code 1 and the following example

### Selection of devices/ Example given:

- continuous power rating of the resistor:  $P = 9,0 \text{ kW}$
- resistance value:  $R = 27 \Omega$
- continuous current of the resistor:  $I = 18 \text{ A}$
- construction with terminals that are protected against contact
- degree of protection IP 20 (mounting on switch cabinet)
- with temperature switch (TS)
- design according to UL

### wanted: resistor

- number of SG = continuous power rating : power per SG =  $9,0 \text{ kW} : 0,5 \text{ kW} = 18 \text{ SG}$
- selection of type series taken from survey on p. T612E
- possible type series: FGF...; FA
- with mounting on a switch cabinet – means on a surface of degree of protection IP 20 you can choose the smaller and low priced alternative FGF, compared to type series FA. If the terminals should be in an attached terminal box, type series FGFKQ is adequate, because of the necessary temperature switch (TS)
- with 18 SG you can select within enclosure size construction height 1 and width 2 (max. poss. 24 SG)
- construction according to UL508: add "U" to the type designation,
- complete type designation is FGFKQU 3121802 – 27 (with 2 device terminals up to 65 A). Type description see p. T624Eff



### Dimensioning example

### Braking resistor

- given:**
- Maximum intermediate circuit voltage 650V :  $U_{ZK} = 650\text{ V}$
  - Smallest allowable resistance value:  
(from data sheet of frequency converter)  $R_{min} = 21\ \Omega$
  - maximum allowable chopper current  $I = \frac{U_{ZK}}{R_{min}} = \frac{650\text{V}}{25\ \Omega} = 26\text{A}$
  - duty cycle factor for braking operation (corresponding to the application),  
for a hoist drive e.g. 40 % DCF referring to a total cycle time of 120 s  
DCF = 40%
  - degree of protection IP 20 in fixed condition
- wanted:**
- short time dissipation of the resistor with 40%DCF  $P = \frac{U^2}{R} = \left(\frac{650\text{V}^2}{25\ \Omega}\right) = 16,9\text{kW}$
  - continuous dissipation = short time dissipation : overload factor (s. p. T616E)
  - continuous dissipation = 20,2 kW : 2,2 = 9,2 kW
  - number of steel-grids = continuous dissipation : dissipation per SG
  - number of steel-grids = 9,2 kW : 0,5 kW  $\approx$  19 SG
- selection of steel-grids:**
- The ohmic value should not be smaller than  $R_{min}$  altogether, since otherwise the allowable chopper current is exceeded!
  - resistance value of a SG = ( $R_{min} \cdot 1,2$ ): SG-number = 25,2  $\Omega$  : 19 = 1,3  $\Omega$ , SG selection of p. T621E = 11 pieces S 23 – 1,2  $\Omega$  and 8 pieces S23 – 1.5  $\Omega$  total ohmic value is 25,2  $\Omega$
- selection of products:**
- With degree of protection IP 20 in fixed condition – series FGF..
  - With 19 steel-grids – construction size 312 19..
  - with 2 terminals up to 35 A, without temperature switch – type FGFG
  - The complete type designation is FGFG 3121902 – 25.2 (s.p. T624Eff)

### Dimensioning example

### Load resistor

- given:**
- Rated voltage U of supply unit:  $U = 3 \times 230/400\text{ V}$
  - rated dissipation:  $P = 15\text{ kW}$
  - star connection, star point in the unit
  - duty cycle factor: DCF = 100%
  - degree of protection IP 23
- wanted:**
- rated current per phase with star connection:  $I_N = \frac{P_N}{\sqrt{3} \times U_N} = \left(\frac{15\text{kW}}{\sqrt{3} \times 400\text{V}}\right) = 21,7\text{A}$
  - nominal value of resistance per phase with star connection:  $R_{wanted} = \frac{U_N}{\sqrt{3} \times I_N} = \left(\frac{400\text{V}}{\sqrt{3} \times 21,7\text{A}}\right) = 10,7\ \Omega$
  - value of resistance in cold condition:  $R_{cold} = 0,95 \times R_{wanted} = 0,95 \times 10,7\ \Omega$   
If the demanded rated dissipation is to be achieved at operating temperature in the range of the resistance tolerance, it is advisable to consider the value of resistance in cold condition.  
 $R_{cold} = 0,95 \times R_{wanted}$   
Then you can make your selection of steel grid.
- selection of steel-grids:**
- Selection of steel-grids of p. T620E by the rated current of 21,7 A: S 21 – 1,0  $\Omega$
  - number of SG per phase = value of resist. in cold condition: ohmic value per SG
  - number of SG = 10,2  $\Omega$  : 1,0  $\approx$  10 SG per phase – 3phases is 30 S 21 – 1
  - value of resistance in cold condition is therefore 3 x 10  $\Omega$
  - resulting rated dissipation: 3 x 10 SG per 0,5 kW = 15 kW
- selection of products:**
- with degree of protection IP 23 – series FS..
  - with 30 steel-grid fixed resistors – size 313 30.. or 322 30..  
(size 313.. is lower, size 322.. is narrower)
  - with 3 terminals (star point in the unit) number of terminals ...03  
with 4 terminals (star point wired on 1 terminal) number of terminals ...04
  - The complete type designation is FS 313 30 03 – 3 x 10,7  
(low unit, star point in the unit) (type series FS s. p. T629E)

Steel-grid fixed resistor elements  
S 1 – S 31

500 W for integration

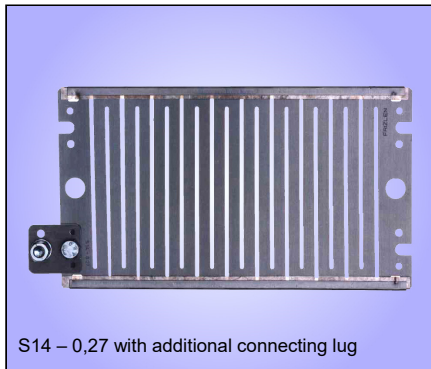

S14 – 0,27 with additional connecting lug



Steel-grid fixed resistor element, degree of protection IP 00, for integration into units. Connection at the resistor

## Technologies

- particularly flat design
- overload resistant
- continuous dissipation 500 W<sup>①</sup>
- energy absorption capacity with  $\Delta T = 300$  K, from 50 up to 70 kW
- integration possible

As accessories we deliver 1 or 2 lugs to each resistor element with connection screws M10 (S 1 - S 10) or M6 (S 11 - S 31). Normally they are not fixed, we will fix them upon request.

We produce steel-grid fixed resistor elements in a wide range of resistance values of 0,022  $\Omega$  up to 6,8  $\Omega$  and a typical power of 500 W<sup>①</sup> per grid.

The given nominal ohmic values are about 8% above the value of cold condition and 7% below the value of operating temperature. The production tolerance is  $\pm 10\%$ .

We achieve a wide range of resistance values and wattage rating by variation of number of steel-grids and resistance values.

Please consider the different designs and construction forms of the following series.

The indicated ratings are valid for an ambient temperature of max. 40° C at sufficient ventilation. The indicated values for the duty cycle factor (%DCF) are preferred values and refer to a maximum total cycle time of 120 s.

You will find further indications for dimensioning of a resistor for short time dissipation in chapter Technical Details pages T613E to T620E.

## Electrical and mechanical data

typical power <sup>①</sup>	% DCF	100	60	40	25	15	6	recomm. connection screws...
	[W]	500	750	1100	1500	2000	3800	
type	$\Omega$	Max. current in amp. with 40°C UT and sufficient ventilation						
S 1 – 0,022	0,022	122	150	183	211	250	344	M10
S 2 – 0,027	0,027	122	150	183	211	250	344	M10
S 3 – 0,033	0,033	122	150	183	211	250	344	M10
S 4 – 0,039	0,039	112	138	168	194	230	315	M10
S 5 – 0,047	0,047	102	126	153	177	210	287	M10
S 6 – 0,056	0,056	94	115	140	163	193	265	M10
S 7 – 0,068	0,068	85	105	127	147	174	240	M10
S 8 – 0,082	0,082	77	96	115	133	158	217	M10
S 9 – 0,10	0,10	70	87	105	121	144	197	M10
S 10 – 0,12	0,12	64	79	96	111	131	180	M10
S 11 – 0,15	0,15	57	71	85	99	117	160	M6
S 12 – 0,18	0,18	52	65	78	90	107	146	M6
S 13 – 0,22	0,22	47	58	71	81	96	132	M6
S 14 – 0,27	0,27	42	53	63	73	86	118	M6
S 15 – 0,33	0,33	38	48	58	68	79	108	M6
S 16 – 0,39	0,39	35	44	53	62	73	100	M6
S 17 – 0,47	0,47	32	40	48	55	65	90	M6
S 18 – 0,56	0,56	29	37	44	51	60	83	M6
S 19 – 0,68	0,68	27	33	41	47	55	76	M6
S 20 – 0,82	0,82	24	30	36	42	49	67	M6
S 21 – 1,0	1,0	22	27	33	38	45	62	M6
S 22 – 1,2	1,2	20	25	30	35	41	56	M6
S 23 – 1,5	1,5	18	22,5	27	31	37	51	M6
S 24 – 1,8	1,8	16,5	20,5	25	28	34	46	M6
S 25 – 2,2	2,2	15	18,5	23	26	31	42	M6
S 26 – 2,7	2,7	13,5	16,5	20	23	27	37	M6
S 27 – 3,3	3,3	12	15	18	21	25	34	M6
S 28 – 3,9	3,9	11	14	16	19	23	31	M6
S 29 – 4,7	4,7	10	12,5	15	18	21	28	M6
S 30 – 5,6	5,6	9,3	11,3	13,7	16	18,6	25	M6
S 31 – 6,8	6,8	8,5	10,5	12,7	14,8	17	23	M6

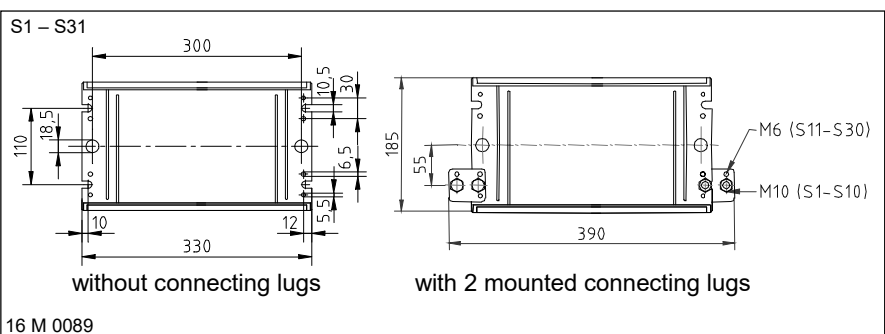
<sup>①</sup> only valid for S3 – S31





Type series FE 31..

1,0 – 22 kW for integration

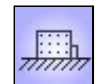

Steel-grid fixed resistor block, degree of protection IP 00 for integration into switch cabinets, units or ventilation ducts. Connection directly at the resistor.

Ⓜ optional, type designation would be FE.U 31..

### Technologies

- for smaller up to middle power rating
- integration and combinations possible
- for mounting into switch cabinet, resistor unit or ventilation duct
- continuous power rating up to 22 kW
- optional with temperature switch (TS), with fast-on connectors 6,3x0,8; type designation would be FEQ 31... (Restrictions see on page T614E)

Each resistor block can be equipped with 2 or more connecting lugs Depending on the current the connection is realized by M6 or M10 screw. The mounting into the switch cabinet, resistor unit or ventilation duct is made by M12 thread bolts.

By means of series connection of steel-grid elements we achieve higher ohmic values; by connecting in parallel of several resistor blocks we achieve higher currents and power ratings.

We can also mount several partial resistors into one resistor block (e.g. 3 phases), separated by insulation rolls.

### Warning:

Not more than 3 resistor blocks should be mounted on top of each other!  
For customer wiring you should use a heat resistant wire.

### Application

An important application is the use as load resistor, where high power rating is demanded by the user.

Further applications are e.g. the mounting of the steel-grid blocks into a ventilation duct with simultaneous forced ventilation by the exhaust air of a diesel engine radiator.

### Electrical and mechanical data

type FE 3.. without , FEQ 3.. with TS	typical power in kW at 40°C and 100% DCF	production range Ω-value		number of steel-grids corresp. to given device size	dimensions in mm L	max. weight in kg
		from	to			
FE. 31503..	1,5	0,07	16	3	180	3,5
FE. 31504..	2,0	0,09	22	4	180	4,0
FE. 31005..	2,5	0,11	28	5	280	5,0
FE. 31007..	3,5	0,15	39	7	280	6,0
FE. 31009..	4,5	0,20	50	9	280	7,0
FE. 31112..	6,0	0,26	67	12	380	8,0
FE. 31114..	7,0	0,31	78	14	380	9,0
FE. 31216..	8,0	0,35	89	16	580	11,0
FE. 31220..	10,0	0,44	112	20	580	13,0
FE. 31224..	12,0	0,53	134	24	580	15,0
FE. 31326..	13,0	0,57	145	26	780	17,5
FE. 31330..	15,0	0,66	168	30	780	19,5
FE. 31334..	17,0	0,75	190	34	780	21,5
FE. 31436..	18,0	0,79	201	36	980	23,5
FE. 31440..	20,0	0,88	224	40	980	25,5
FE. 31444..	22,0	0,97	246	44	980	27,5

This table represents only a selection of our program. All numbers of steel-grids between 2 pc. (1,0 kW) and 44 pc. (22 kW) corresponding to our types are available. Type code and selection of units see Technical Details pages T613E to T620E.

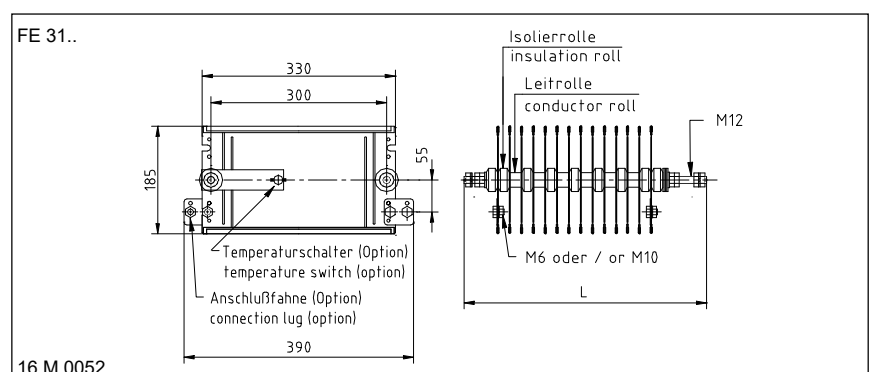

### Example of dimensioning and selection of a special unit:

One phase load resistor: 5,0 kW for 48 V DC; resistance value 0,46 Ω;  
selected: 9 S5 -0,047 +1 S4-0,039 Ω = 0,46 Ω;  
type FE 3111002 - 0,46 with typical power 5,0kW, connection on 2 connection lugs M10 at the resistor, with temperature switch (2 connections)

FEQ 311 10 04 - 0,46

- ohmic value ± 10%
- number of connection lugs (02) + 02 für TS
- number of steel-grids
- type series (with TS)



Type series FKE 31..

1,0 – 22 kW for integration



FKE 3100502



Steel-grid fixed resistor, degree of protection IP 00, with side plates for integration into a switch cabinet. Connection directly at the resistor.

© optional, the type designation would be FKE.U 31..

## Technologies

- especially compact construction form, dimensions depend on number of installed steel-grids.
- small to middle power rating
- continuous power rating up to 22 kW
- integration into switch cabinet possible
- temperature switch optional (TS), with fast-on connectors 6,3x0,8; type designation would be FKEQ 31... (Restrictions see on page T614E)

Each resistor can be delivered with 2 or more connection lugs. Depending on the current the lugs are equipped with M6 or M10 screws. The resistor is mounted in a cabinet by means of the two side plates.

Mounting of several partial resistors (e.g. 3-phases) into one resistor unit is possible. They are separated by insulation rolls.

You will find suggestions for the dimensioning of the resistor for short time load in chapter "Technical Details", pages T613E to T620E.

For customer wiring you should use a heat resistant wire.

## Application

Customized solutions like integrating a resistor unit into a switch cabinet, when a very compact construction form is needed.

Thus various kinds of solutions are possible for many applications such as:

- load resistors
- charging or discharging resistors
- braking resistors
- starting and regulating resistors etc.
- damping resistors

## Electrical and mechanical data

type FKE 31.. without TS, FKEQ 31.. with TS	typical power in kW at 40°C and 100% DCF	production range Ω-value		number of steel-grids corresp. to given device size	dimensions in mm		max. weight in kg
		from	to		A	B	
FKE. 31503..	1,5	0,07	16	3	147	162	4,4
FKE. 31504..	2,0	0,09	22	4	167	182	5,0
FKE. 31005..	2,5	0,11	28	5	187	202	5,6
FKE. 31007..	3,5	0,15	39	7	227	242	6,8
FKE. 31009..	4,5	0,20	50	9	267	282	7,9
FKE. 31112..	6,0	0,26	67	12	327	342	9,7
FKE. 31114..	7,0	0,31	78	14	367	382	10,8
FKE. 31216..	8,0	0,35	89	16	407	423	12,0
FKE. 31220..	10,0	0,44	112	20	487	503	14,3
FKE. 31224..	12,0	0,53	134	24	567	583	16,6
FKE. 31326..	13,0	0,57	145	26	607	623	17,8
FKE. 31330..	15,0	0,66	168	30	687	703	20,1
FKE. 31334..	17,0	0,75	190	34	767	783	22,4
FKE. 31436..	18,0	0,79	201	36	807	823	23,6
FKE. 31440..	20,0	0,88	224	40	887	903	25,9
FKE. 31444..	22,0	0,97	246	44	967	983	28,2

This table represents only a selection of our program. All numbers of steel-grids between 2 pc. (1,0 kW) and 44 pc. (22 kW) corresponding to our types are available. Type code and selection of units see Technical Details pages T613E to T620E.

The dimensions A and B increase by 20 mm per each steel-grid element (SG)

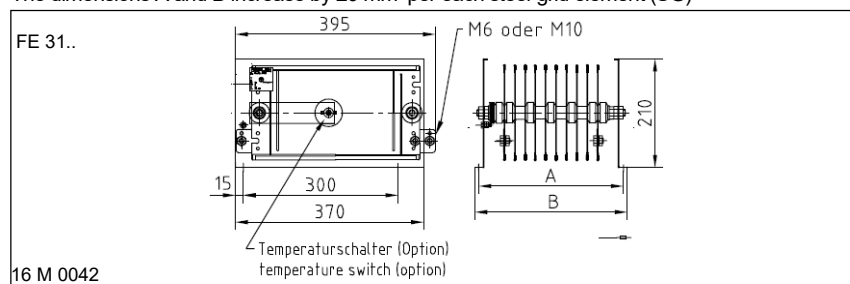

## Example of dimensioning and selection of a specific unit:

Three phase load resistor: for 3 x 3,0 kW = 9,0 kW for 3 x 230/400 V; 50 Hz, 3 x 13 A, 3 x 17,8 Ω, (Rcold=16,9) starpoint on connection lug:  
selected: 3 S26 – 2,7 Ω + 4 S25 – 2,2 Ω = 16,9 Ω; 3 x 7 SG  
type FKE 3122104 – 3 x 17,7 with typical power 3 x 3,0 kW, connection on 4 connection lugs at the resistor (value Rwanted)

FKE 312 21 04 - 3 x 17,8

ohmic value ± 10%  
number of connection lugs  
number of steel-grids  
type series



Type series FGF.. 31..

1,0 – 22 kW with 2 terminals



Steel-grid fixed resistor unit, degree of protection IP 20 if mounted on an appropriate surface, with zinc plated steel enclosure. It is equipped with max. 2 terminals of different kinds mounted in or at the enclosure or in the attached terminal box. Some types can be provided with a temperature switch or with an integrated thermal overload relay or DC/POWERSWITCH. For your selection of a specific type you will find tables on the next page.

① if mounted on an appropriate surface

③ optional (not for FGFG), type designation would be FGF..U 31..

## Technologies

- low priced type, very compact design
- continuous power rating up to 22 kW
- for mounting on top of a switch cabinet (all types besides FGFD..)
- for integration into a switch cabinet with terminals that are protected against contact (type FGFD..)
- units may be wall or plate mounted, perforated steel sheet at the front, top and bottom, terminals at the bottom.
- terminal type and size selectable according to mounting place and connection technics
- optional with temperature switch (type FGF.Q) (Restrictions see on page T614E)
- optional with thermal overload relay (type FGFT)

## Application

These units are fitting especially for mounting on, beside or in a switch cabinet by their relatively flat and compact construction in 6 widths with various connections and monitoring possibilities (Please mind the description of the types).

An important application is the use as braking resistor for motor/generator drive of motors with frequency converters, where high power rating is combined with low budget solution.

You will find suggestions for the dimensioning of the resistor for short time load at chapter Technical Details, pages T613E to T620E.

## Warning

When resistor is integrated into a cabinet we recommend to provide a corresponding forced ventilation by the user for better removal of larger dissipations.

## Details of the different types

### Type FGFG:

Version with 2 flat type terminals up to max. 35 A rated current in the attached terminal box with cable gland. An additional temperature switch is not possible.

### Type FGFK(Q):

Version like FGFG, with a bigger attached terminal box with cable glands, the space is sufficient for 2 terminals up to M8 (max. 115 A rated current), and for 2 additional porcelain terminals for an optional temperature switch (FGFKQ).

### Type FGFL(Q):

Version, where all terminals are mounted on the terminal strip inside the housing. Terminals up to M8 (max. 115 A rated current) are accessible after disassembling a part of the cover. If equipped with temperature switch, there are 2 additional porcelain terminals on the terminal strip (Type FGFLQ). No cable glands.

### Type FGFD(Q):

Construction with feed-through terminals up to max. 65 A that are protected against contact and directly fixed on the side plate. It is a space-saving solution for integrating into a switch cabinet. If equipped with temperature switch there are 2 additional protected feed-through terminals (FGFDQ).

### Type FGFT:

Version with integrated thermal overload relay in the attached terminal box with cable glands up to max. 80 A rated current. With integrated short-circuit and overload signalling. Connection directly at the overload relay. Minimum current is 1 A.

## Rated current and cross section of terminals and devices

See technical details on page T618E.



Monitoring options of the type series FGF.. 31..

1,0 – 22 kW with 2 terminals

**1. Signalling–no disconnection!**

This warning has to be considered by the customer, e.g. by a warning or disconnection of the mains through the customer. Details, on page T615E.

**1a) with temperature switch (FGF.Q)**

Different types can be equipped for temperature monitoring with a temperature switch which monitors an overloading of the resistor by a normally closed contact free of potential (NCC, Restrictions see on page T614E).

Connections pls. look at picture 1a)

**1b) with thermal overload relay (FGFT)**

An eventual overload of the resistor is monitored by the thermal overload relay which is mounted in the attached terminal box. This is accomplished by NCC and NOC contacts. Also for signalling high short time peak power.

Connections pls. look at picture 1b)

Pic. 1a)

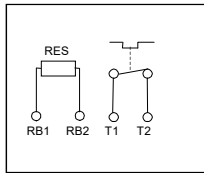

P 1b)

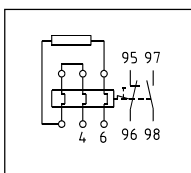

**Decision matrix**

type	FGFG	FGFK	FGF KQ	FGFL	FGF LQ	FGFD	FGF DQ	FGFT
properties								
with temperature switch (TS)			X		X		X	
thermal overload relay (up to max. 80 A rated current)								X
DC-POWERSWITCH (up to max. 40 A)								
terminals in attached terminal box with PG-strain relief	X	X	X					X
terminals inside unit (without PG- strain relief)				X	X			
flat terminals up to max. 35 A	X	X	X	X	X			
device terminal up to max. 60 A		X	X					
bolt terminals M6 up to max. 60 A		X	X	X	X			
bolt terminals M8 up to max. 115 A		X	X	X	X			
feed-thru terminals up to max. 65 A						X	X	
PA cage clamp terminals up to max. 30 A		X	X					

**Electrical and mechanical data**

types	typical power in kW at 40°C and 100% DCF	production range		number of steel-grids corresp. to given device size	dimensions in mm					max. weight in kg
		Ω-value	from		to	A	B	C1 ①	C2 ②	
FGF.. 31503..	1,5	0,07	16	3	170	195	207	230	255	6,0
FGF.. 31504..	2,0	0,09	22	4	170	195	207	230	255	6,5
FGF.. 31005..	2,5	0,11	28	5	270	295	307	330	355	7,5
FGF.. 31007..	3,5	0,15	39	7	270	295	307	330	355	8,5
FGF.. 31009..	4,5	0,20	50	9	270	295	307	330	355	9,5
FGF.. 31112..	6,0	0,26	67	12	370	395	407	430	455	12
FGF.. 31114..	7,0	0,31	78	14	370	395	407	430	455	13
FGF.. 31216..	8,0	0,35	89	16	570	595	607	630	655	18
FGF.. 31220..	10,0	0,44	112	20	570	595	607	630	655	20
FGF.. 31224..	12,0	0,53	134	24	570	595	607	630	655	22
FGF.. 31326..	13,0	0,57	145	26	770	795	807	830	855	29
FGF.. 31330..	15,0	0,66	168	30	770	795	807	830	855	31
FGF.. 31334..	17,0	0,75	190	34	770	795	807	830	855	33
FGF.. 31436..	18,0	0,79	201	36	970	995	1007	1030	1055	40
FGF.. 31440..	20,0	0,88	224	40	970	995	1007	1030	1055	42
FGF.. 31444..	22,0	0,97	246	44	970	995	1007	1030	1055	44

This table represents only a selection of our program. All numbers of steel-grids between 2 pc. (1,0 kW) and 44 pc. (22 kW) corresponding to our types are available. Type code and selection of units see Technical Details pages T613E to T620E.

Example: 2 device terminals + temperature switch (2 terminals) => FGFKQ 31...04

① dim. C1 is only valid for Type FGFD (dimension sheet 16M0442)

② dim. C2 is only valid for Type FGFG (dimension sheet 16M0041)

③ dim. C3 valid for types FGFK (dim. sheet 16M0410), FGFT (dim. sheet 16M0086) for type FGFL dim. „B“ is valid, as design without term.box (dim. sheet 16M0424)

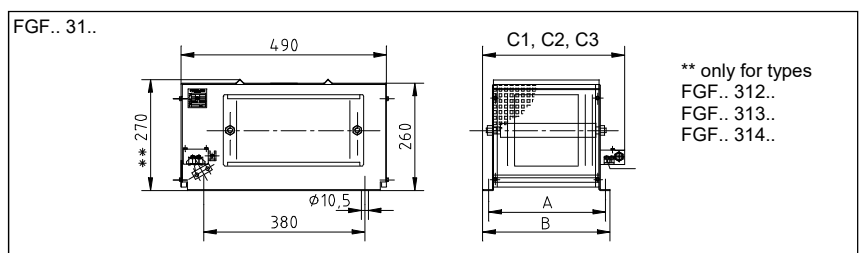





Type series FGHD 31..

1,0 – 12 kW with 2 terminals,  
for integration into switch cabinet

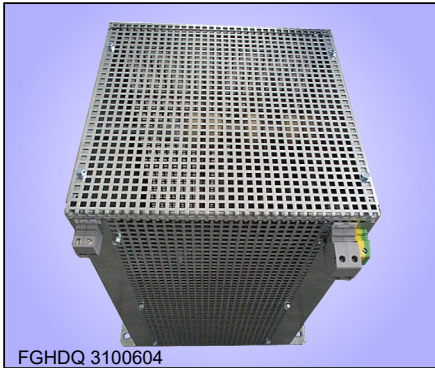

Steel-grid fixed resistor, degree of protection IP 20 in fixed condition, in zinc plated steel sheet enclosure with 2 feed-through terminals for the resistor, that are integrated into the side-panel end plates, protected against contact according to BGV A2. Optional also with temperature switch (TS).

① if mounted on an appropriate surface

② optional, type designation would be FGHD.U 31..

### Technologies

- low priced type, very compact design
- for middle power ratings up to 12 kW
- for space saving integration into a switch cabinet
- optional with temperature switch wired on two terminals. Type designation would be FGHDQ. 31... (Restrictions see on page T614E)

The given power rating values are valid for 100%CD (continuous dissipation). For short time operation you will find the values in the following table as a function of the duty cycle factor (DCF). Just multiply by the corresponding overload factor (OLF).

DCF	60%	40%	25%	15%	6%
OLF	1,5	2,2	3,0	4,0	7,6

These overload factors are valid for a total cycle time of maximum 120 s

You will find further details in chapter Technical Details pages T613E to T620E.

### Application

An important application is the use as braking resistor for motor/generator drive of motors with frequency converters, where middle power ratings are to be integrated into a switch cabinet in a space saving way.

### Warning

The user has to make sure that large dissipations are removed. We recommend an adequate forced ventilation.

### Electrical and mechanical data

Type FGHD. 31.. without TS, FGHDQ. 31.. with TS	typical power in kW at 40°C and 100% DCF	production range Ω-value		max. number of steel-grids corresp. to given device size	dimensions in mm		max. weight in kg
		from	to		A	B	
FGHD..31502..	1,0	0,05	11	2	170	195	6,0
FGHD..31503..	1,5	0,07	16	3	170	195	6,5
FGHD..31504..	2,0	0,09	22	4	170	195	7,0
FGHD..31005..	2,5	0,11	28	5	270	295	7,5
FGHD..31007..	3,5	0,15	39	7	270	295	8,5
FGHD..31009..	4,5	0,20	50	9	270	295	9,5
FGHD..31112..	6,0	0,26	67	12	370	395	12
FGHD..31114..	7,0	0,31	78	14	370	395	13
FGHD..31216..	8,0	0,35	89	16	570	595	18
FGHD..31220..	10,0	0,44	112	20	570	595	20
FGHD..31224..	12,0	0,53	134	24	570	595	22

This table represents only a selection of our programm. All numbers of steel-grids corresponding to our types between 2 pc. (1,0 kW) and 24 pc. (12 kW) are available. Type code and selection of units see Technical Details pages T613E to T620E.

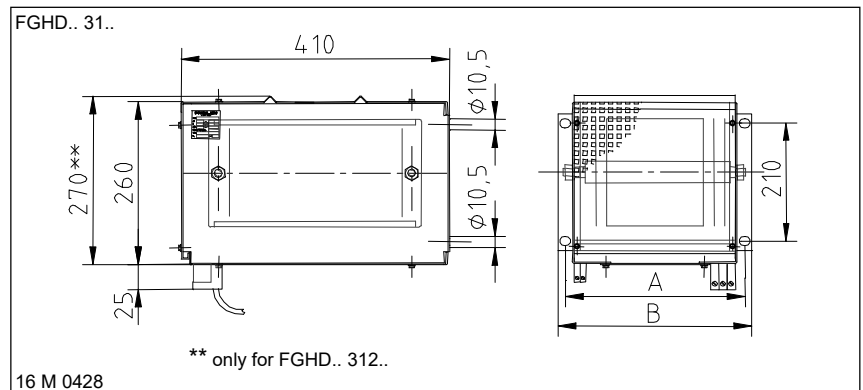

16 M 0428

### Example of dimensioning and selection of a specific unit:

One phase braking resistor for frequency converter drive with temperature switch, short time dissipation 24 kW at 15% DCF, total cycle time shorter than 120 s, intermediate voltage circuit 650V; resistance value 18 Ω; calculating of continuous dissipation: 24 kW : 4,0 = 6,0 kW; chosen: FGHDQ 311 12 04 - 18

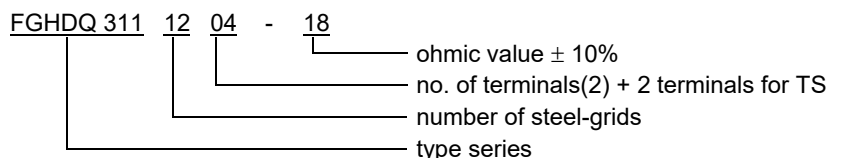



Type series FK 3..

1,5 – 66 kW with up to 40 terminals

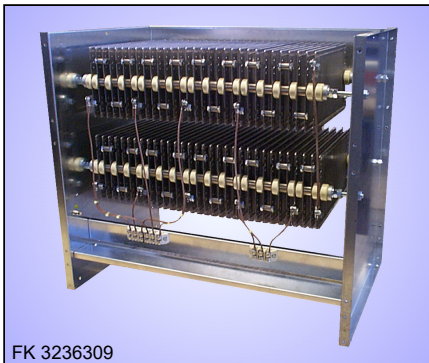

Steel-grid fixed resistor unit, degree of protection IP 00 with 2 side-panel end plates out of zinc plated steel sheet. Ceramic isolated flat or bolt terminals of 35 A up to 400 A in variable combinations available.

Ⓜ optional, type designation would be FK.U 3..

### Technologies

- for middle and high power ratings
- Up to 40 FK-terminals
- continuous dissipation up to 66 kW
- for floor-level mounting
- optional with temperature switch (TS), type designation would be then FKQ 3... (Restrictions see on page T614E)

The necessary terminals are mounted on a terminal strip in the lower part of the device.

You will find suggestions for the dimensioning of the resistor for short time load at chapter Technical Details, pages T613E to T620E.

### Application

This construction is especially appropriate for big power ratings that are to be low in weight and in price. The same applies to the installation in closed electrotechnical rooms, where the degree of protection IP 00 is allowed.

### Special design

- dimensioning for forced ventilation supplied by the user
- special construction forms for integration into exhaust air ducts for engine radiators

### Option

- with temperature switch wired on 2 terminals, type then FKQ...

### Electrical and mechanical data

Type FK 3.. without TS, FKQ. 3.. with TS	max. typical power in kW at 40°C and 100% DCF	production range Ω-value		max. number of steel-grids corresp. to given type size	dimensions in mm			max. weight in kg
		from	to		A	B	C	
FK. 31114..	7,0	0,31	78	14	370	395	460	19
FK. 31224..	12,0	0,53	134	24	570	595	460	26
FK. 31334..	17,0	0,75	190	34	770	795	460	38
FK. 31444..	22,0	0,97	246	44	970	995	460	45
FK. 32128..	14,0	0,16	156	28	370	395	710	31
FK. 32248..	24,0	0,27	268	48	570	595	710	46
FK. 32368..	34,0	0,38	380	68	770	795	710	70
FK. 32488..	44,0	0,49	492	88	970	995	710	80
FK. 33272..	36,0	0,18	403	72	570	595	960	62
FK. 33302..	51,0	0,25	570	102	770	795	960	87
FK. 33432..	66,0	0,32	739	132	970	995	960	115

This table only represents the maximum number of steel-grids of the specific size of unit and the corresponding maximum typical power. All numbers of steel-grids corresponding to our types between 3 pc. (1,5 kW) and 132 pc. (66 kW) are available. Type code and selection of units see Technical Details pages T613E to T620E.

Type	Max. number of terminals up to					
	FK 35A	BK M6 60A	BK M8 115A	BK M10 170A	BK M10 220A	BK M12 400A
FK. 3.1..	16	10	8	7	7	7
FK. 3.2..	24	16	14	12	12	11
FK. 3.3..	32	23	20	17	17	16
FK. 3.4..	40	30	26	22	22	20

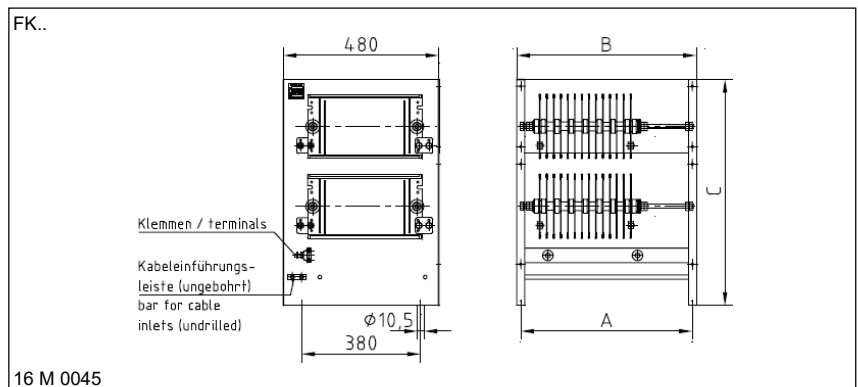

16 M 0045

### Example of dimensioning and selection of a specific unit:

see Technical Details pages T613E to T620E



Type series FKK.. 3..

5,0 – 250 kW, in duct design

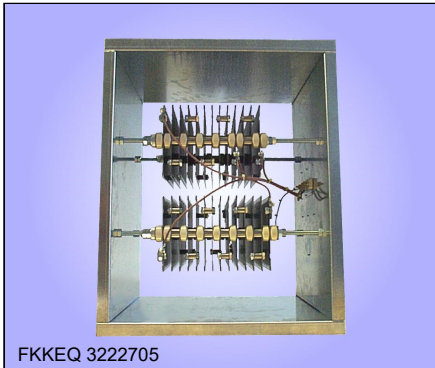

Steel-grid fixed resistor unit, degree of protection IP 00 integrated in a duct section for integration by the user into existing or new exhaust air installations, in a zinc steel sheet duct with attached terminal box and optional temperature switch.

### Technologies

- for middle or high power ratings
- low priced solution for existing forced ventilation provided by the customer
- continuous dissipation up to 250 kW
- prepared for integration into customer's duct.
- For exhaust air temperatures up to 60°C
- optional with temperature switch wired on two terminals, type designation would be FKKEQ 3... (Restrictions see on page T614E)

We provide ceramic insulated flat or bolt terminals of 35 A up to 400 A and mount the required terminals into an attached terminal box.

On behalf of a large range of dimensions, vertically as well as horizontally, we realize all kinds of duct cross sections.

### Application

An important application is the use as load resistor for emergency power units.

In cases where a diesel power unit is to be protected by a base load against "wear" due to small load or when necessary or compulsory load tests of efficiency of the power unit must be accomplished.

We are specialists in customized solutions!

### Special designs

- integration into ducts, provided by the customer, type series FKKF..
- integration kit for integration by the user
- up to 5 blocks can be mounted on top of each other
- with integration of 2 resistor sets in a row
- with wind indicator monitoring

### Electrical and mechanical data

Type FKK. 3.. without TS, FKKEQ. 3.. with TS	max. typical power in kW at 40°C and 100% DCF	max. number of steel-grids corresp. to given device combination (n x m)	dimensions in mm					max. weight in kg	
			duct height		duct width				
			max. block # (n)	A	B	max. SG-# (m)	C	D	
F.. 31215..	15,0	15	1	415	475	15	415	475	25
F.. 32236..	37,5	36	2	450	510	18	450	510	35
F.. 32242..	45,0	42	2	550	610	21	500	560	47
F.. 32248..	50,0	48	2	600	660	24	550	610	50
F.. 32354..	60,0	54	2	650	710	27	630	690	55
F.. 33384..	95,0	84	3	690	750	28	650	710	85
F.. 33390..	100	90	3	720	780	30	700	760	88
F.. 33399..	112,5	99	3	750	810	33	765	825	95
F.. 34444..	160	144	4	900	960	36	810	870	135
F.. 34460..	180	162	4	1000	1060	41	900	960	150

This table represents only a selection of what can be combined concerning duct dimensions. Other combinations and other dimensions are available, of course. All numbers of steel-grids corresponding to our types between 15 pcs. (15 kW) und 264 pcs. (250 kW) are available. Type code and selection of units see Technical Details pages T613E to T620E.

Please let us know your specific case of application. We will meet exactly your requirements.

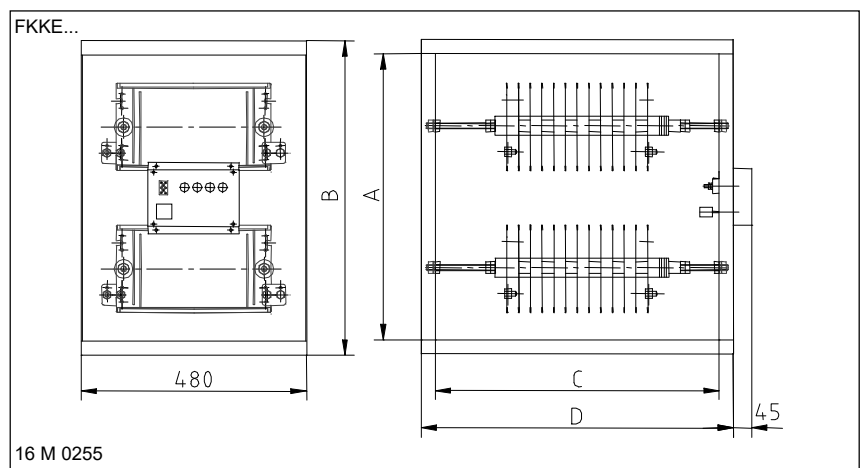

### Example of dimensioning and selection of a specific unit:

Please contact us, we will be glad to work on a detailed offer for you!



Type series FA 3.. / FS 3..

1,5 – 66 kW with several terminals



FA... Steel-grid fixed resistor unit, degree of protection IP 20 without weatherproof roof,

FS... Steel-grid fixed resistor unit, degree of protection IP 23 with weatherproof roof

In completely closed zinc sheet enclosure with protective grid at the top and bottom. Ceramic insulated flat or bolt terminals of 35 A up to 400 A in variable combinations available.

© optional, the type designation would be FA.U 3.. / FS.U 3..

## Technologies

- for middle and high power ratings
- Up to 40 FK-terminals
- continuous dissipation up to 66 kW
- for floor-level mounting
- for outdoor location (FS...)
- optional with temperature switch (TS) wired on two terminals, the type designation would be F.Q. 3... (Restrictions see on page T614E)

The necessary terminals are mounted on a terminal strip in the lower part of the device and are accessible after demounting a cover.

By the use of 12 different enclosure sizes – with 3 heights and 4 widths we can well adapt the construction form to the given space. In the range between 14 and 88 steel-grids you can make your choice between smaller and lower forms.

You will find suggestions for the dimensioning of the resistor for short time load at chapter Technical Details, pages T613E to T620E.

## Application

An important application is the use as braking resistor for motor/generator drive of motors with frequency converters, where big power ratings are necessary for outdoor location combined with degree of protection IP 20 or IP 23.

## Special design

- For special applications also in a four block design
- Enclosure additionally varnished in RAL 7032 or other colours
- Connection parts and enclosure out of stainless steel 1.4301/AISI304

## Electrical and mechanical data

Type FA 3.. / FS 3.. without, FAQ 3.. / FSQ 3.. with TS	max. typical power in kW at 40°C and 100% DCF	production range Ω-value		max. number of steel-grids corresp. to given device size	dimensions in mm				max. weight in kg
		from	to		A	B	C	D only IP23	
F.. 31114..	7,0	0,31	78	14	370	395	460	520	26
F.. 31224..	12,0	0,53	134	24	570	595	460	520	36
F.. 31334..	17,0	0,75	190	34	770	795	460	520	51
F.. 31444..	22,0	0,97	246	44	970	995	460	520	61
F.. 32128..	14,0	0,16	156	28	370	395	710	770	41
F.. 32248..	24,0	0,27	268	48	570	595	710	770	61
F.. 32368..	34,0	0,38	380	68	770	795	710	770	86
F.. 32488..	44,0	0,49	492	88	970	995	710	770	101
F.. 33272..	36,0	0,18	403	72	570	595	960	1100	82
F.. 33302..	51,0	0,25	570	102	770	795	960	1100	112
F.. 33432..	66,0	0,32	739	132	970	995	960	1100	138

This table only represents the maximum number of steel-grids of the specific size of unit and the corresponding maximum typical power. All numbers of steel-grids corresponding to our types between 3 pc. (1,5 kW) and 132 pc. (66 kW) are available. Type code and selection of units see Technical Details pages T613E to T620E.

Type	Max. number of terminals up to					
	FK 35A	BK M6 60A	BK M8 115A	BK M10 170A	BK M10 220A	BK M12 400A
F.. 3.1..	16	10	8	7	7	7
F.. 3.2..	24	16	14	12	12	11
F.. 3.3..	32	23	20	17	17	16
F.. 3.4..	40	30	26	22	22	20

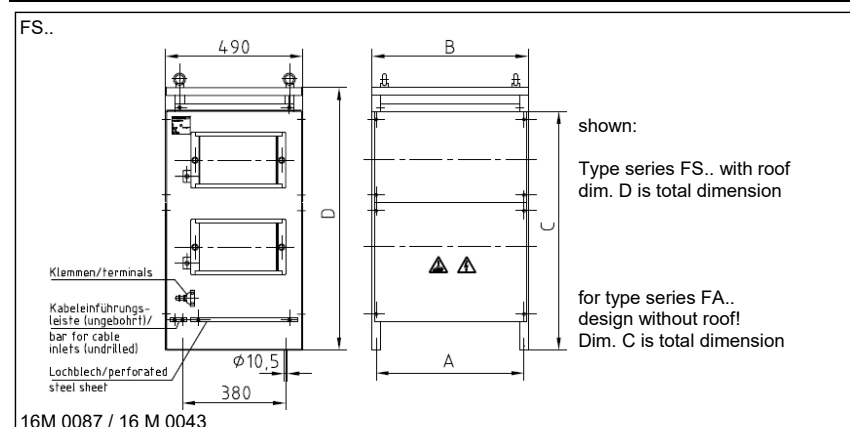

## Example of dimensioning and selection of a specific unit:

see Technical Details pages T613E to T620E





Type series FS 319.. / FS 320..

0,5 – 5,0 kW with 2 terminals



Steel-grid fixed resistor unit, degree of protection IP 23 with weatherproof roof, appropriate for outdoor mounting, in zinc steel sheet enclosure, for connection with 2 terminals, with several holes for cable glands, that are closed by rubber sockets.

### Technologies

- for smaller power ratings
- compact construction form
- continuous dissipation up to 5,0 kW
- units may be wall mounted , horizontal mounting not admitted
- for outdoor mounting (FS...)  
(Restrictions see on page T614E)

The necessary terminals are mounted in the lower part of the device and are accessible after demounting the cover. We can provide 2 flat or 2 bolt terminals M6 or M8.

You will find suggestions for the dimensioning of the resistor for short time load at chapter Technical Details, pages T613E to T620E.

### Application

On behalf of small dimensions and compact construction form this type series is especially appropriate as load resistor for small power ratings, if degree of protection IP 23 is necessary.

A lot of applications are possible because of the high degree of protection and the wall mounting, such as the outdoor mounting.

### Special design

- degree of protection IP 20 (without roof), type FA 319.. / FA 320..

### Electrical and mechanical data

type	max. typical power in kW at 40°C and 100% DCF	production range $\Omega$ -value		max. number of steel-grids corresp. to given device size	dim. in mm F	drills for cable lead-throughs M	max. weight in kg
		from	to				
FS 3190602	3,0	0,11	33,6	6	200	1 x PG 13,5 + 1 x PG 16 + 3 x PG21	9,5
FS 3201002	5,0	0,22	56,0	10	335		12

This table only represents the maximum number of steel-grids of the specific size of unit and the corresponding maximum typical power. All numbers of steel-grids corresponding to our types between 1pc. (0,5 kW) and 10 pc. (5,0 kW) are available.

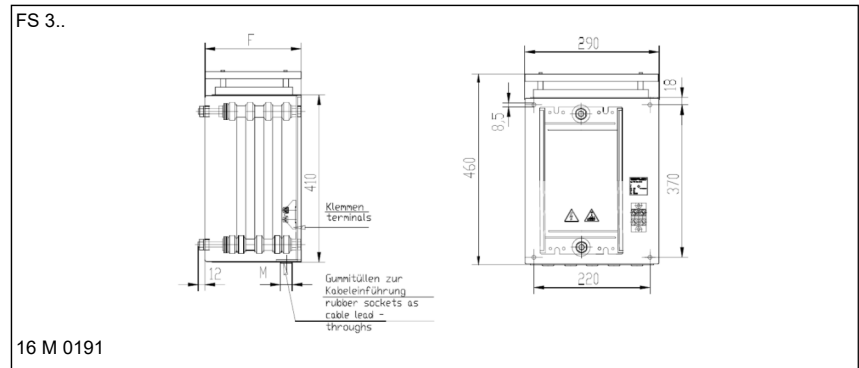

### Example of dimensioning and selection of a specific unit:

One phase starting resistor as constant series resistor for motor 220 V DC; 8,5 kW, 51 A; resistor value 0,72  $\Omega$ ; continuous dissipation approx. 1,9 kW; chosen: FS 3190402 – 0,72 with continuous dissipation 2 kW; this corresponds to 4 steel-grids S12 - 0,18  $\Omega$  = 0,72  $\Omega$ , connection with 2 bolt terminals M6

FS 319 04 02 - 0,72

- ohmic value  $\pm$  10%
- number of terminals
- number of steel-grids
- type series





Type series FAV 3../FSV 3..

70 – 500 kW with several terminals



FAV... Steel-grid fixed resistor unit, degree of protection IP 20, without weatherproof roof, air outlet on top,

FSV... Steel-grid fixed resistor unit, degree of protection IP 23 with weatherproof roof, for outdoor location, air outlet at the side via air deflectors in the upper area.

In completely closed zinc sheet enclosure with protective grid at the bottom and powered ventilation by an integrated ventilator. With air flow monitoring by wind indicator relay. Ceramic insulated flat or bolt terminals of 35A up to 400A in variable combinations available or copper busbar.

**Technologies**

- for high power ratings
- power ventilated by integrated 230/400 V; 50 Hz axial flow fan
- for floor-level location
- continuous dissipation up to 500 kW
- paralleling of 2 or more units for even higher powers
- for outdoor location (FS...)

The necessary terminals are mounted on a terminal strip in the lower part of the device and are accessible after demounting a cover. Behind the cover is a unbored conduit strip in which you can drill the needed holes for cable glands.

By the use of steel-grid elements with a typical power of 1100 W up to 1700 W per steel-grid with forced ventilation we cover a power range of up to 500 kW per unit. Higher power ratings can be achieved by parallel connection of several devices.

**Application**

An important application is the use as load resistor for the testing of emergency power installations. Protection degree IP 20 is sufficient for installing in factory rooms, IP23 is necessary for outdoor location.

**Special design**

- with integrated switching devices in an attached switch cabinet to control the partial resistors
- with 2 temperature switches wired on terminals.
- special voltages of fan
- please ask for devices with higher power ratings or other construction forms
- mobile, for test areas by rollers

**Electrical and mechanical data**

type FAV 3.. FSV 3..	max. typical power in kW at 40°C and 100% DCF	max. number of steel-grids corresp. to given size of device	dimensions in mm						max. weight in kg
			A	B	C	D	E	F	
F.V 38568..	75	68	1200	1240	800	700	795	770	142
F.V 38602..	110	102	1500	1540	800	700	795	770	185
F.V 38776..	185	176	1400	1450	955	850	995	970	265
F.V 38864..	250	264	1700	1750	955	850	995	970	370
F.V 38976..	300	176	1820	1875	1190	1000	1004	980	350
F.V 39052..	500	352	2230	2285	1190	1000	1004	980	480

This table represents only the maximum number of steel-grids of the specific size of unit and the corresponding maximum typical power. Many specifications depending on customer requirement are possible. For the application as load resistor please look on page T431E.

**Standard resistors as brake - resistor**

type FAV..	partial resistors in kW (examples)	FAV..	
FAV 3856608	75		
FAV 3860010	2 x 50		
FAV 3860208	110		
FAV 3873610	2 x 70		
FAV 3877608	185		
FAV 3881610	2 x 100		
FAV 3885208	250		
FAV 3897412	3 x 100		
FAV 3897608	300		
FAV 3908810	2 x 200		
FAV 3905208	500		
			16 M 0182 type 385-388; 16M-0786-00-001 type 389-390

type FSV..	partial resistors in kW (examples)	FSV..
FSV 3856808	75	
FSV 3867210	2 x 40	
FSV 3860208	110	
FSV 3874408	150	
FSV 3877608	185	
FSV 3880408	220	
FSV 3885208	250	
FSV 3897610	2 x 150	
FSV 3897608	300	
FSV 3908808	400	
FSV 3905208	500	
		16 M 0088 type 385-388; 16M-0786-00-002 type 389-390



Steel-grid fixed resistor elements  
S 301G – S 321G

500 W, up to 200 kW, for integration  
0,0022 up to 0,1 ohm

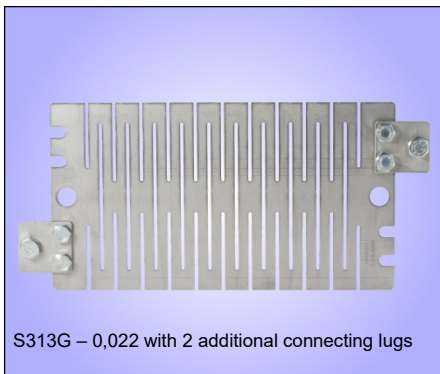

S313G – 0,022 with 2 additional connecting lugs



Steel-grid fixed resistor element, degree of protection IP 00 for integration into units. Connection at the resistor.

<sup>②</sup> in preparation

### Technologies

- particularly flat design
- high overload capacity
- continuous dissipation 500 W <sup>①</sup>
- energy absorption capacity with  $\Delta T = 300$  K, from 150 up to 200 kW
- integration possible

As accessories we deliver 1 or 2 lugs to each resistor element with connection screws M12. Normally they are not fixed, we will fix them upon request. Type designation: S301GF1 – S321GF1 (1 lug mounted), S301GF2 – S321GF2 (2 lugs mounted).

We produce steel-grid fixed resistor elements in a range of resistance values of 0,0022  $\Omega$  up to 0,1  $\Omega$  and a typical power of 500 W <sup>①</sup> per grid.

The given nominal ohmic values are about 8% above the value of cold condition and 7% below the value of operating temperature. The production tolerance is  $\pm 10\%$ .

The indicated ratings are valid for an ambient temperature of max. 40° C at sufficient ventilation. The indicated values for the duty cycle factor (%DCF) are preferred values and refer to a maximum total cycle time of 120 s.

You will find further indications for dimensioning of a resistor for short time dissipation in chapter Technical Details pages T613E to T620E.

Remark: Higher ohmic values with lower energy absorption capacity are available on request.

### Electrical and mechanical data

typical power <sup>①</sup>	% ED	100	15	10	6	3	1	energy-absorption-capacity
	[W]	500	2000	2750	3800	6000	10000	
type	$\Omega$	Max. current in amp. with 40°C UT and sufficient ventilation						kWs
S301G – 0,0022	0,0022	400	800	938	1103	1386	1789	200
S302G – 0,0027	0,0027	400	800	938	1103	1386	1789	200
S303G – 0,0033	0,0033	389	778	913	1073	1348	1741	200
S304G – 0,0039	0,0039	358	716	840	987	1240	1601	200
S305G – 0,0047	0,0047	326	652	765	899	1130	1459	180
S306G – 0,0056	0,0056	299	598	701	824	1035	1336	180
S307G – 0,0068	0,0068	271	542	636	748	939	1213	180
S308G – 0,0082	0,0082	247	494	579	681	855	1104	180
S309G – 0,010	0,010	224	447	524	616	775	1000	180
S310G – 0,012	0,012	204	408	479	563	707	913	180
S311G – 0,015	0,015	183	365	428	503	632	816	165
S312G – 0,018	0,018	167	333	391	459	577	745	165
S313G – 0,022	0,022	151	302	354	416	522	674	165
S314G – 0,027	0,027	136	272	319	375	471	609	165
S315G – 0,033	0,033	123	246	289	339	426	550	165
S316G – 0,039	0,039	113	226	266	312	392	506	165
S317G – 0,047	0,047	103	206	242	284	357	461	165
S318G – 0,056	0,056	94	189	222	260	327	423	150
S319G – 0,068	0,068	86	171	201	236	297	383	150
S320G – 0,082	0,082	78	156	183	215	271	349	150
S321G – 0,1	0,1	71	141	166	195	245	316	150

<sup>①</sup> only valid for S303G – S321G

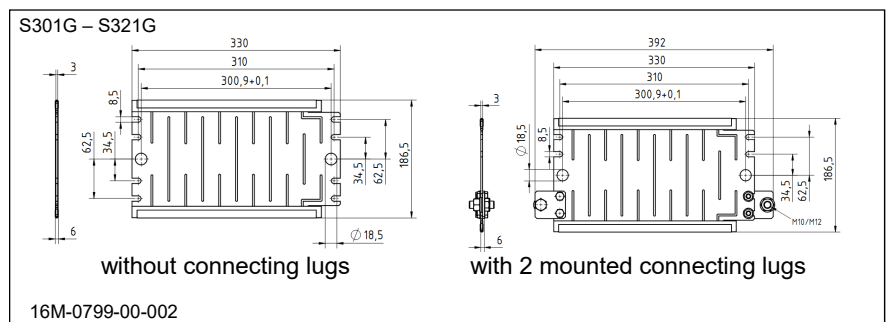

16M-0799-00-002

Steel-grid fixed resistor elements  
S301A – S321A

150 - 200 kW for integration,  
0,0022 up to 0,1 ohm

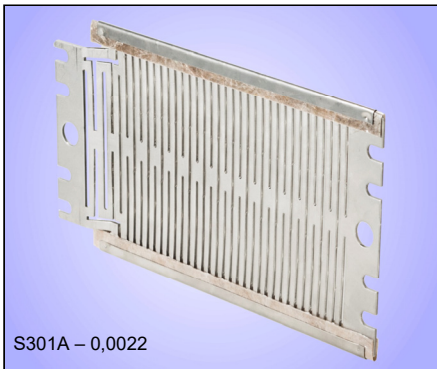

Steel-grid fixed resistor element, degree of protection IP 00 with angled connection side, for integration into units for extremely compact construction, with optimized energy absorption capacity. Connection at the resistor.  
Registration: German patented design no. 20 2012 010 188.9

② in preparation

**Technologies**

- Design for building extremely compact resistor combinations, optimized for high energy absorption capacity
- high overload capacity
- energy absorption capacity with  $\Delta T = 300\text{ K}$ , from 150 up to 200 kW
- integration possible

Steel-grid resistor elements are produced in a range of resistance values of 0,0022  $\Omega$  up to 0,1  $\Omega$ . With the German patented design we can realize extremely compact resistor combinations with very space-saving dimensions. Please look at our pages T635E and T637E.

The given nominal ohmic values are about 8% above the value of cold condition and 7% below the value of operating temperature. The production tolerance is  $\pm 10\%$ .

The connections are realised by screws M12 at the attached connecting lugs.

The indicated short time power values can be absorbed within the given time and are valid for a ambient temperature of max. 40°C and for an excess temperature of 300 K.

A following break of 20 min. for cooling off with sufficient ventilation must be accepted before a new energy load can follow.

Remark: Higher ohmic values with lower energy absorption capacity are available on request.

**Electrical and mechanical data**

	ED[s]	1 s	2 s	3 s	5 s	10 s	20 s	60 s
type	$\Omega$	Short time dissipation in kW with 40°C UT and sufficient ventilation						
S301A – 0,0022	0,0022	200	100	65	40	20	10	3,5
S302A – 0,0027	0,0027	200	100	65	40	20	10	3,5
S303A – 0,0033	0,0033	200	100	65	40	20	10	3,5
S304A – 0,0039	0,0039	200	100	65	40	20	10	3,5
S305A – 0,0047	0,0047	180	90	60	36	18	9	3,2
S306A – 0,0056	0,0056	180	90	60	36	18	9	3,2
S307A – 0,0068	0,0068	180	90	60	36	18	9	3,2
S308A – 0,0082	0,0082	180	90	60	36	18	9	3,2
S309A – 0,010	0,010	180	90	60	36	18	9	3,2
S310A – 0,012	0,012	180	90	60	36	18	9	3,2
S311A – 0,015	0,015	165	84	55	42	16,5	8,3	3,0
S312A – 0,018	0,018	165	84	55	42	16,5	8,3	3,0
S313A – 0,022	0,022	165	84	55	42	16,5	8,3	3,0
S314A – 0,027	0,027	165	84	55	42	16,5	8,3	3,0
S315A – 0,033	0,033	165	84	55	42	16,5	8,3	3,0
S316A – 0,039	0,039	165	84	55	42	16,5	8,3	3,0
S317A – 0,047	0,047	165	84	55	42	16,5	8,3	3,0
S318A – 0,056	0,056	150	75	50	37,5	15	7,5	2,7
S319A – 0,068	0,068	150	75	50	37,5	15	7,5	2,7
S320A – 0,082	0,082	150	75	50	37,5	15	7,5	2,7
S321A – 0,1	0,1	150	75	50	37,5	15	7,5	2,7

Remark: The given short time power can be absorbed in the given time with a following break of 15 min.

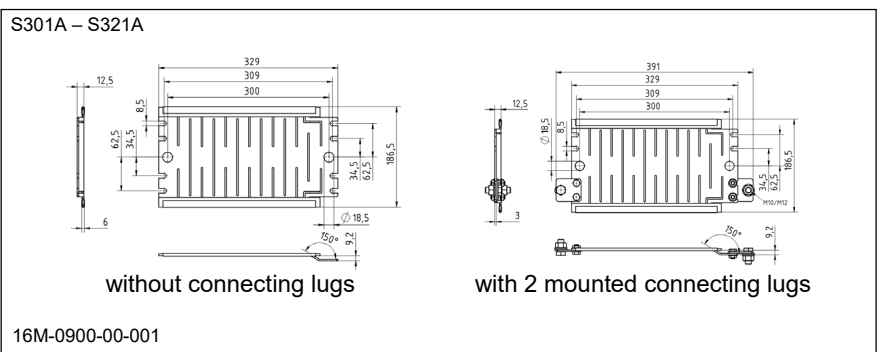



Type series FEY 31..

1,0 – 19,5 kW, up to 7,8 MWs, for integration, low ohmic values, high energy absorption capacity



FEYQ 3111004 with 2 connecting lugs and TS

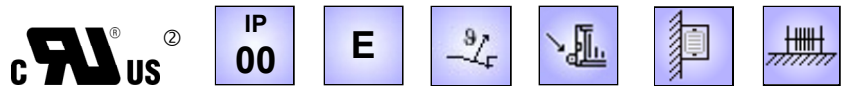

Steel-grid fixed resistor block in protection degree IP 00 for high energy absorption capacity, for integration into switch cabinets, devices or ventilation ducts. Connection directly at the resistor.

② in preparation

### Technologies

- for high energy absorption capacity
- for high continuous currents
- integration and combinations possible
- for integration into switch cabinet
- continuous dissipation up to 19,5 kW
- energy absorption capacity with  $\Delta T = 300$  K, up to 7,8 MWs
- optional with temperature switch (TS) with fast-on connections 6,3x0,8, type FEYQ 31... (Restrictions see on page T614E)

Each resistor device can be equipped with 2 or more connecting lugs. The connections are made with screws M12 at the mounted connecting lugs. The integration in a switch cabinet, machine or in a duct is made by means of 2 threaded bolts M12.

We achieve a wide range of resistance values and wattage rating by variation of number of steel-grids and resistance values.

The given power rating values are valid for 100%CD (continuous dissipation). For short time operation you will find the values in the following table as a function of the duty cycle factor (DCF). Just multiply by the corresponding overload factor (OLF).

DCF	60%	40%	25%	15%	6%
OLF	1,5	2,2	3,0	4,0	7,6

These overload factors are valid for a total cycle time of maximum 120 s

### Warning:

Not more than 3 resistor blocks should be mounted on top of each other!

For customer wiring you should use a heat resistant wire.

### Application

- filter resistor
- FRT resistor
- Crowbar resistor
- load resistor
- charge/discharge resistor
- current limiting resistor

### Electrical and mechanical data

Type	one-time energy absorption capacity in kW		typical power in kW at 40°C and 100%ED	production range mΩ-value		max. number of steel-grids corresp. to given device size	dim. in mm L	max. weight in kg
	from	up to		from	to			
FEY 3.. without TS, FEYQ 3.. with TS								
FEY. 31502..	300	400	1,0	4,4	200	2	180	3,6
FEY. 31004..	600	800	2,0	8,8	400	4	280	6,0
FEY. 31006..	900	1200	3,0	13,2	600	6	280	9,9
FEY. 31008..	1200	1600	4,0	17,6	800	8	280	12,3
FEY. 31110..	1500	2000	5,0	22	1000	10	380	14,9
FEY. 31112..	1800	2400	6,0	26,4	1200	12	380	17,3
FEY. 31216..	2400	3200	8,0	35,2	1600	16	580	22,5
FEY. 31221..	3150	4200	10,5	46,2	2100	21	580	28,5
FEY. 31326..	3900	5200	13,0	57,2	2600	26	780	35,0
FEY. 31330..	4500	6000	15,0	66	3000	30	780	39,8
FEY. 31433..	4950	6600	16,5	72,6	3300	33	980	44,0
FEY. 31436..	5400	7200	18,0	79,2	3600	36	980	47,6
FEY. 31439..	5850	7800	19,5	85,8	3900	39	980	51,2

This table represents only a selection of our program. All numbers of steel-grids between 2 pcs.. (1,0 kW) and 39 pcs. (19,5 kW) corresponding to our types are available. For the type code and selection of units you will be assisted from us.

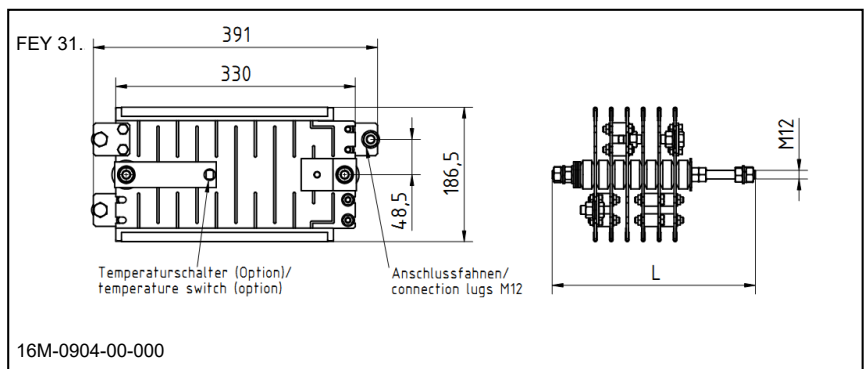

16M-0904-00-000

### Example of dimensioning and selection of a special unit:

Three phase filter resistor, for 3 x 1,0 kW and 3 x 690 V AC, resistor value 3 x 35 mΩ; selected: 3 x 2 S312G – 0,018 with each 0,5 kW ( $\sum 3 \times 1$  kW) = 3 x 36 mΩ; type FEY 3100606 – 3 x 0.036 with continuous dissipation 3 x 1,0 kW, connection on 6 connection lugs with screws M12 at the resistor

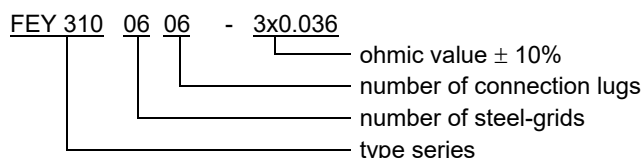





Type series FEP 31..

150 kW up to 7,2 MWs for integration, compact sizing, high energy absorption capacity

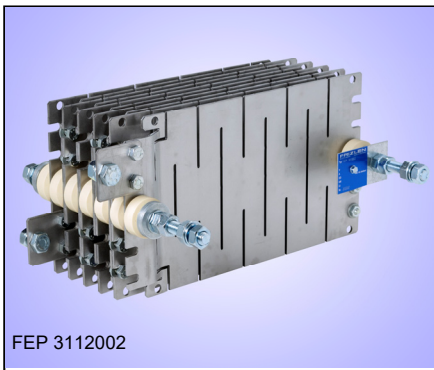

Steel-grid fixed resistor block in protection degree IP 00 for very high energy absorption capacity or high short time dissipation in a extremely compact design. For integration into a switch cabinet. Connection at the resistor. Registered design protected construction. Not recommended for continuous dissipation or DCF application. Registration: German patented design no. 20 2012 010 188.9

② in preparation

### Technologies

- for very high energy absorption capacity, for a short time within seconds
- for short time high currents
- integration and combinations possible
- for integration into a switch cabinet
- energy absorption capacity with  $\Delta T = 300 K$ , up to 7,2 MWs

Each resistor device can be equipped with 2 or more connecting lugs. The connections are made with screws M12 at the mounted connecting lugs. The mounting in the switch cabinet, machine or in the duct is made by means of 2 threaded bolts M12.

The applied steel-grid resistor elements are produced in a range of resistance values of 2,2 mΩ up to 100 mΩ (please look on page T633E). With the German patented design we can realise extremely compact resistor combinations with very space-saving dimensions.

The given nominal ohmic values are about 8% above the value of cold condition and 7% below the value of operating temperature. The production tolerance is  $\pm 10\%$ .

With the variation of the number of resistor elements and ohmic values a wide range of the resulting ohmic values and energy absorption capacities can be covered. The connections are realized by screws M12 at the attached connecting lugs.

The indicated short time power values can be absorbed within the given time and are valid for a room temperature of max. 40°C and for an excess temperature of 300 K. A following break of 20 min. for cooling off with sufficient ventilation must be accepted before a new energy load can follow.

### Application

- FRT resistor
- LVRT resistor
- crowbar resistor
- charge-/discharge resistor
- emergency stop resistor

### Electrical and mechanical data

type	one-time energy absorption capacity in kW		max. current in kA for 1 s at 40°C	production range mΩ-value		max. number of steel-grids corresp. to given device size	dim. in mm L	max. weight in kg
	from	to		from	to			
FEP 31502..	300	400	9,5	4,4	200	2	180	4,8
FEP 31504..	600	800	9,5	8,8	400	4	180	7,3
FEP 31006..	600	1200	9,5	13,2	400	6	280	9,8
FEP 31008..	900	1600	9,5	17,6	600	8	280	12,3
FEP 31010..	1200	2000	9,5	22	800	10	280	14,8
FEP 31012..	1800	2400	9,5	26,4	1200	12	280	17,3
FEP 31114..	2100	2800	9,5	30,8	1400	14	380	19,8
FEP 31118..	2700	3600	9,5	39,6	1800	18	380	24,8
FEP 31120..	3000	4000	9,5	44	2000	20	380	27,3
FEP 31224..	3600	4800	9,5	52,8	2400	24	580	32,3
FEP 31228..	4200	5600	9,5	61,6	2800	28	580	37,3
FEP 31232..	4800	6400	9,5	70,4	3000	32	580	42,3
FEP 31236..	5400	7200	9,5	79,2	3600	36	580	47,3

This table represents only a selection of our program. All numbers of steel-grids between 2 pcs. (300 kW) and 36 pcs. (7,2 MWs) corresponding to our types are available. For the type code and selection of units you will be assisted from us.

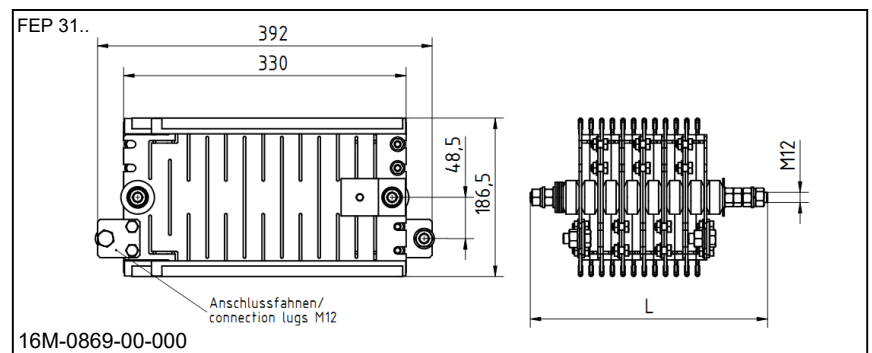

### Example of dimensioning and selection of a special unit:

FRT load resistor, three-phase, for short time 3 x 1 MWs within 3-4 sec., repeated every 15 min., each phase 1,0 MWs for 1000 V DC, resistor value 0,13 Ω; selected: 6 x S313A – 0,022 with each 165 kW (Σ 990 kW) = 0,132 Ω; type FEP 3121806 – 3 x 0.13, connection on 6 lugs with connection screws M12 at the resistor

FEP 312 18 06 - 3 x 0.13

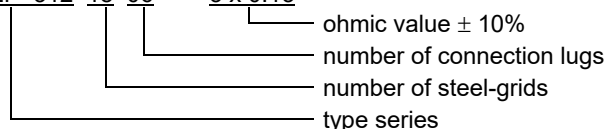





Type series FKEY 31..

1,0 – 19,5 kW, up to 7,8 MWs, for integration,  
low ohmic values, high energy absorption capacity



Steel-grid fixed resistor block, with side plates, in protection degree IP 00 for high energy absorption capacity, for integration into switch cabinets. Connection directly at the resistor.

② in preparation

### Technologies

- for high energy absorption capacity
- for high continuous currents
- continuous dissipation up to 19,5 kW
- for integration into switch cabinets
- optional with temperature switch (TS) with fast-on connections 6,3x0,8, type FKEYQ 31.. (Restrictions see on page T614E)

Each resistor device can be equipped with 2 or more connecting lugs. The connections are made with screws M12 at the mounted connecting lugs. The resistor is mounted by means of two side plates.

We achieve a wide range of resistance values and wattage rating by variation of number of steel-grids and resistance values.

Combining of several partial resistors (e.g. 3 phases) in one resistor unit is possible. They are separated by insulation rolls.

You will find suggestions for the dimensioning of the resistor for short time load in chapter "Technical details", please look on page T613E up to T618E. For customer wiring you should use a heat resistant wire.

### Application

Customized solutions like integrating a resistor unit into a switch cabinet, when a very compact design is needed.

Thus various kinds of solutions are possible for many applications such as:

- FRT resistor
- crowbar resistor
- load resistor
- charge-/discharge resistor
- current limiting resistor

### Electrical and mechanical data

type	one-time energy absorption capacity in kW		typical power in kW at 40°C and 100% ED	production range mΩ-value		max. number of steel-grids corresp. to given device size	dim. in mm		max. weight in kg
	from	up to		from	to		A	B	
FKEY 31004..	300	400	1,0	4,4	200	2	140,5	157	8,0
FKEY 31006..	600	800	2,0	8,8	400	4	184,5	201	10,3
FKEY 31008..	900	1200	3,0	8,8	600	6	228,5	245	12,8
FKEY 31110..	1200	1600	4,0	13,2	800	8	272,5	289	15,3
FKEY 31112..	1500	2000	5,0	17,6	1000	10	316,5	333	17,8
FKEY 31216..	1800	2400	6,0	22	1200	12	360,5	377	20,3
FKEY 31221..	2400	3200	8,0	26,4	1600	16	448,5	465	25,3
FKEY 31326..	3150	4200	10,5	30,8	2100	21	566,5	583	31,5
FKEY 31326..	3900	5200	13,0	39,6	2600	26	676,5	693	37,8
FKEY 31330..	4500	6000	15,0	48,4	3000	30	764,5	781	42,8
FKEY 31433..	4950	6600	16,5	52,8	3300	33	830,5	847	46,5
FKEY 31436..	5400	7200	18,0	61,6	3600	36	896,5	913	50,3
FKEY 31439..	5850	7800	19,5	85,8	3900	39	962,5	979	54,2

This table represents only a selection of our program. All numbers of steel-grids between 2 pcs.. (1,0 kW) and 39 pcs. (19,5 kW) corresponding to our types are available. For the type code and selection of units you will be assisted by us.

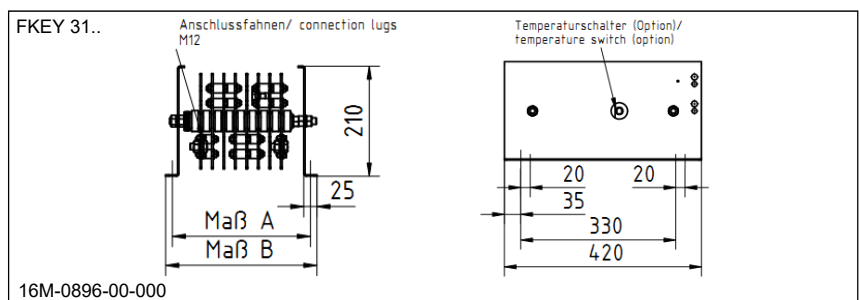

### Example of dimensioning and selection of a special unit:

Load resistor for battery, single phase, for continuous dissipation 10 kW, for 32 V DC, resistor value 0,1 Ω;  $R_{cold} = 0,95 \times R_{soll} = 0,95 \times 0,1 \Omega = 0,095 \Omega$ ; selected: 20 x S305G – 0,0047 = 0,94 Ω, with each 0,5 kW in total 10 kW, type FKEY 3122002 – 0.1, connections on 2 lugs with connection screws M12 at the resistor

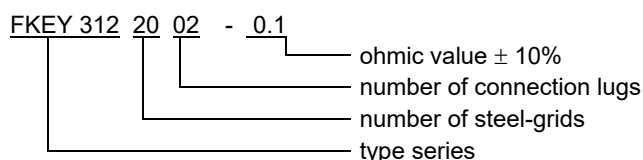

Type series FKEP 31..

150 kW – 7,2 MW for integration,  
compact sizing, high energy absorption capacity

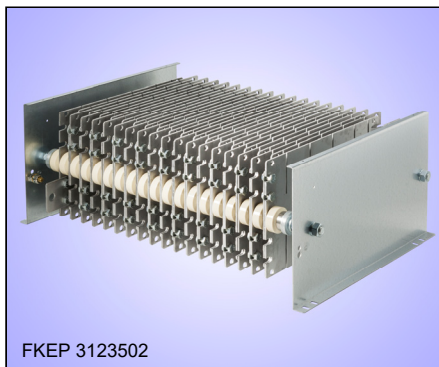

Steel-grid fixed resistor block with side plates in protection degree IP 00 for very high energy absorption capacity or high short time dissipation in an extremely compact design. For integration into a switch cabinet. Connection at the resistor. Registered design protected construction. Not recommended for continuous dissipation or DCF application.

Registration: German patented design no. 20 2012 010 188.9

Ⓜ in preparation

**Technologies**

- for very high energy absorption capacity, for a short time within seconds
- for short time high currents
- integration and combinations possible
- for integration into switch cabinet
- energy absorption capacity with  $\Delta T = 300 K$ , up to 7,2 MWs

Each resistor device can be equipped with 2 or more connecting lugs. The connections are made with screws M12 at the mounted connecting lugs. The resistor is mounted by means of two side plates.

The applied steel-grid resistor elements are produced in a range of resistance values of 2,2 mΩ up to 100 mΩ. (see page T633E). With the German patented design we can realise extremely compact resistor combinations with very space-saving dimensions.

With the variation of the number of resistor elements and ohmic values a wide range of the resulting ohmic values and energy absorption capacities can be covered.

The indicated short time power values can be absorbed within the given time and are valid for a room temperature of max. 40°C and for an excess temperature of 300 K. A following break of 20 min. for cooling off with sufficient ventilation must be accepted before a new energy load can follow.

**Application**

- FRT resistor
- LVRT resistor
- Crowbar resistor
- Discharging resistor
- Emergency stop resistor

**Electrical and mechanical data**

type	one-time energy absorption capacity in kW		max. current in kA for 1 s at 40°C	production range mΩ-value		max. number of steel-grids corresp. to given device size	dim. in mm		max. weight in kg
	from	up to		from	to		A	B	
FKEP31502.	300	400	0,6 - 4,7	4,4	200	2	141	157,5	8,0
FKEP31504.	600	800	0,6 - 4,7	8,8	400	4	166	182,5	10,3
FKEP31006.	900	1200	0,6 - 4,7	13,2	600	6	191	207,5	12,8
FKEP31008.	1200	1600	0,6 - 4,7	17,6	800	8	216	232,5	15,3
FKEP31010.	1500	2000	0,6 - 4,7	22	1000	10	241	257,5	17,8
FKEP31012.	1800	2400	0,6 - 4,7	26,4	1200	12	266	282,5	20,3
FKEP31114.	2100	2800	0,6 - 4,7	30,8	1400	14	291	307,5	22,8
FKEP31118.	2700	3600	0,6 - 4,7	39,6	1800	18	341	357,5	27,8
FKEP31120.	3000	4000	0,6 - 4,7	44	2000	20	375,5	392	30,3
FKEP31224.	3600	4800	0,6 - 4,7	52,8	2400	24	426	442,5	35,3
FKEP31228.	4200	5600	0,6 - 4,7	61,6	2800	28	476	492,5	40,3
FKEP31232.	4800	6400	0,6 - 4,7	70,4	3000	32	526	542,5	45,3
FKEP31236.	5400	7200	0,6 - 4,7	79,2	3600	36	576	592,5	50,3

This table only represents only a selection of our program. All numbers of steel-grids between 2 pcs. (300 kW) and 36 pcs. (7,2 MW) corresponding to our types are available. Details about the max. energy absorption capacity please look on page T633E. For the type code and selection of units you will be assisted by us.

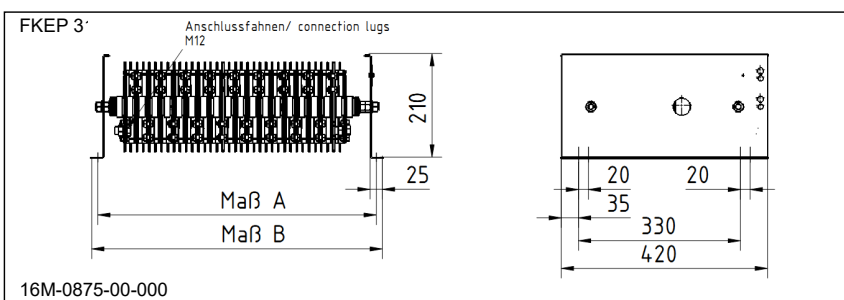

**Example of dimensioning and selection of a special unit:**

FRT load resistor, single phase, for a short time 3 MWs within 3-4 s, repeated every 15 min.: 3,0 MWs for 1200 V DC, resistor value 1,12 Ω; selected: 20 x S318A – 0,056 with each 150 kW (Σ 3000 kW) = 1,12 Ω type FKEP 3112002 – 1,12, connections on 2 lugs with connection screws M12 at the resistor

